

# Answers

## Chapter 1

### 1.1 The Cartesian Plane, pages 9–11

5. A(3, 6), B(7, 0), C(1, -2), D(0, 0), E(-2, -3), F(-3, 4)  
 6. G(3, 4), H(0, 7), I(-5, 2), J(-5, -2), K(4, -6), L(-7, 0)  
 7. a) T b) X c) U d) W e) Y f) V  
 8. a) E b) A c) F d) B e) C f) D

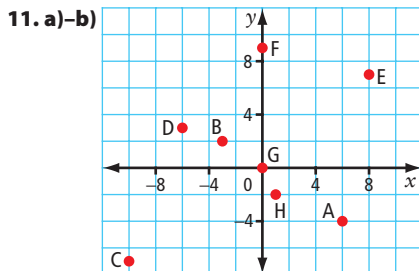
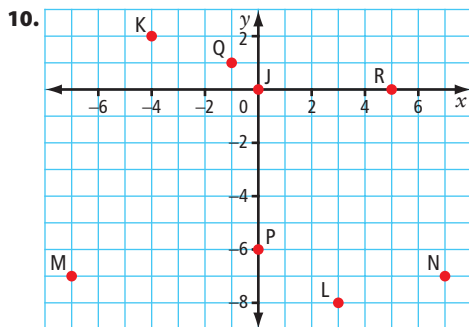
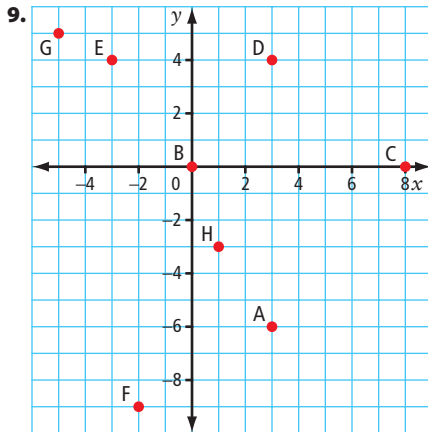

- c) Answers may vary, depending on the accuracy of your predictions.  
 d) F, G Point F lies on the  $y$ -axis, and G lies on the origin.  
 12. a) They form a vertical dotted line.  
 b) The  $x$ -coordinate of each point is  $-7$ .  
 c) Answers may vary. For example,  $(-7, -2)$ ,  $(-7, -4)$   
 13. a) square b) quadrant I c) 4 units  
 d) A and B have the same  $x$ -coordinate, C and D have the same  $x$ -coordinate, A and D have the same  $y$ -coordinate.

14. 12 square units. The rectangle is 4 units by 3 units.

Area = length  $\times$  width =  $4 \times 3 = 12$  square units

15. a) 20 times (assumes that they do not cross diagonally)

b) Yes c) Yes, W

16. a) No b) M c) M(0, -3)

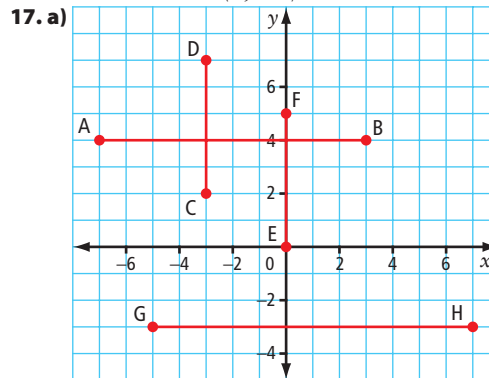

- b) AB: 10 units, CD: 5 units, EF: 5 units, GH: 12 units

18. a)  $(-80, 26)$  b)  $(-88, 26)$  c)  $(-89, 33)$

### 1.2 Create Designs, pages 15–17

3. P: (2, 0), (4, 4), (0, 4); Q:  $(-1, -2)$ ,  $(-1, -6)$ , (3, -2), (3, -6); R:  $(-2, -3)$ ,  $(-6, -3)$ ,  $(-8, -1)$ ,  $(-4, -1)$ ; S:  $(-3, -1)$ ,  $(-1, 1)$ ,  $(-6, 2)$ ,  $(-4, 4)$

4. A: (3, 2), (3, 5),  $(-2, 5)$ ; B: (4, -1), (1, -4), (5, -7), (8, -4); C:  $(-3, -3)$ ,  $(-3, -5)$ ,  $(-1, -5)$ , (3, -1), (1, -1), (1, 1); D: (0, 2),  $(-1, 4)$ ,  $(-4, 3)$ ,  $(-2, 0)$

5. a) A $(-4, -3)$ , B $(-8, -5)$ , C $(-6, -7)$ , D $(-5, -5)$ , E(2, -1), F(3, -5), G(4, -3)

- b) Connect A to B to C to D, connect A to E to G to D to A, connect C to F to G.

6. Answers may vary.

Design A: connect (1, 0) to (3, 1) to (5, 0), connect (6, 1) to (4, 2) to (6, 3), connect (5, 4) to (3, 3) to (1, 4), connect (0, 3) to (2, 2) to (0, 1), colour the triangles.

Design B: connect (0, 3) to  $(-3, 3)$  to  $(-6, 3)$  to  $(-6, -1)$  to  $(-3, -1)$  to (0, -1) to  $(-1, 1)$  to (0, 3), connect  $(-3, 3)$  to  $(-3, -1)$ , colour the right side of the design.

Design C: Plot and connect all 8 vertices around the outside edge of the design. Connect  $(-3, -2)$  to  $(-3, -6)$ , connect  $(-5, -2)$  to  $(-5, -6)$ , colour the left and right rectangles.

Design D: connect (0, -3) to (0, -7) to (3, -7) to (6, -7) to (6, -3) to (3, -3) to (0, -3), colour the rectangle on the right.

7. math

- 8. a)** Answers may vary. For example, the word BOAT.  
 B: connect (2, 6) to (2, 2) to (8, 2) to (5, 4) to (8, 6) to (2, 6).  
 O: connect (-2, 2) to (-2, 6) to (-8, 6) to (-8, 2) to (-2, 2), and connect (-8, 6) to (-2, 2).  
 A: connect (-2, -2) to (-8, -2) to (-8, -6) to (-2, -6) to (-3, -4) to (-2, -2), and connect (-5, -2) to (-5, -6).  
 T: connect (2, -2) to (8, -2) to (8, -6) to (2, -6) to (2, -2), connect (4, -2) to (4, -6), and connect (6, -2) to (6, -6).

**b)** Answers may vary.

- 9.** Answers may vary. For example, plot and join the following points in order: (1, 6), (2, 6), (2, 4), (3, 4), (3, 6), (4, 6), (4, 4), (5, 4), (5, 3), (4, 3), (4, 1), (3, 1), (3, 3), (1, 3). Join (1, 3) to (1, 6).

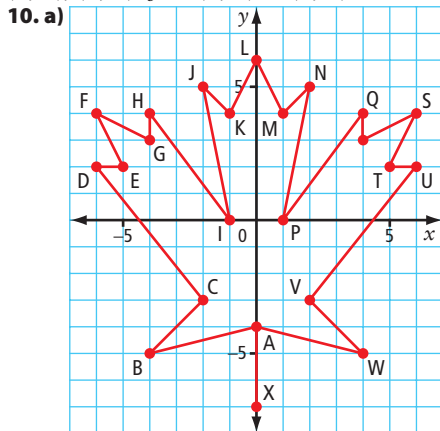

**b)** a maple leaf

- 11. a)** (21, -27) **b)** (28, -15) **c)** (59, 8) **d)** (37, -5)

- 12. a)-b)** ( $l, w$ ): (1, 17), (2, 16), (3, 15), (4, 14), (5, 13), (6, 12), (7, 11), (8, 10), (9, 9)

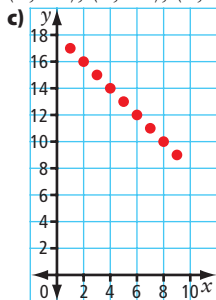

**d)** Quadrant I. Length and width are always positive values.

- 13. a)-b)** (0, 6) and (5, 0), (0, 5) and (6, 0), (0, 4) and (7, 0), (0, 3) and (8, 0), (0, 2) and (9, 0), (0, 1) and (10, 0)

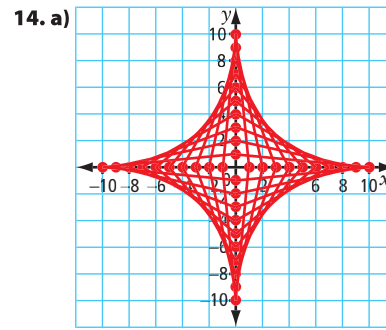
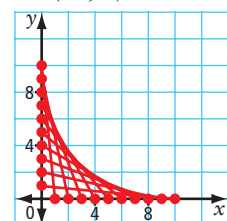

- b)** The ordered pairs on the y-axis for the shapes in quadrant I and III have the same x-values and opposite y-values. The ordered pairs on the x-axis for the shapes in quadrants I and III have opposite x-values and the same y-values. **c)** a 4-point star shape with concave sides

### 1.3 Transformations, pages 24–29

- 3. a)** 8 units right, 2 units down

**b)** 1 unit left, 6 units up

- 4. a)** 6 units right, 5 units up

**b)** 6 units left, 4 units up

- 5. a)-b)** P'(7, 4), Q'(7, -2), R'(6, 1), S'(5, 2)

**c)** translation: 3 units right, 6 units down

- 6. a)-b)** W'(-1, 0), X'(1, -2), Y'(-2, -3), Z'(-4, -1)

**c)** translation: 6 units left, 3 units down

**7.** No. Each vertex is not the same distance from the line of reflection,  $l$ , as its reflected vertex.

**8.** Yes. Each vertex is the same distance from the line of reflection,  $n$ , as its reflected vertex.

**9.** The line of reflection is the vertical line that crosses the x-axis at 1.

**10.** The line of reflection is the horizontal line that crosses the y-axis at 1.

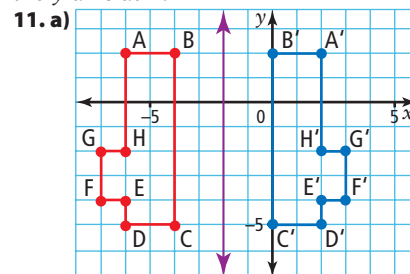

- b)** A'(2, 2), B'(0, 2), C'(0, -5), D'(2, -5), E'(2, -4), F'(3, -4), G'(3, -2), H'(2, -2)

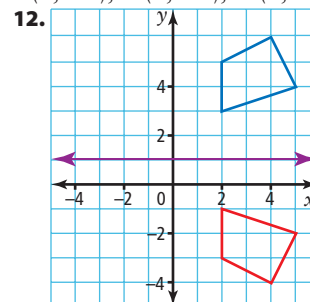

- 13. a)**  $H(-3, -2)$ ,  $A(-1, -3)$ ,  $T(-3, -6)$ ;  $H'(7, -4)$ ,  $A'(5, -3)$ ,  $T'(7, 0)$   
**b)**  $180^\circ$  counterclockwise  
**14. a)**  $T(-1, 2)$ ,  $A(-3, 2)$ ,  $P(-3, 5)$ ,  $E(-1, 6)$ ;  $T'(1, 4)$ ,  $A'(1, 6)$ ,  $P'(4, 6)$ ,  $E'(5, 4)$   
**b)**  $270^\circ$  counterclockwise  
**15. a)**  $(-4, -4)$  **b)**  $90^\circ$  clockwise,  $270^\circ$  counterclockwise  
**16. a)**  $(2, -1)$  **b)**  $180^\circ$  clockwise,  $180^\circ$  counterclockwise  
**17. a)**

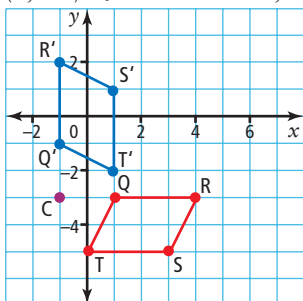

- b)**  $Q'(-1, -1)$ ,  $R'(-1, 2)$ ,  $S'(1, 1)$   $T'(1, -2)$

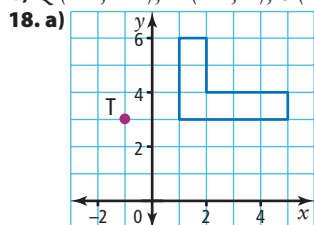

- b)** The rotation image is identical to the original image.

- 19. a)** image B, image C, image D  
**b)-c)** STUV to image B: 2 units right, 5 units up;  
 STUV to image C: 5 units left, 1 unit down;  
 STUV to image D: 6 units left, 5 units up

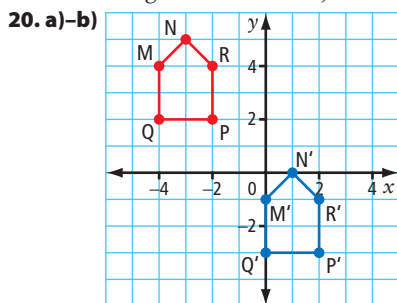

- c)** 4 units right, 5 units down

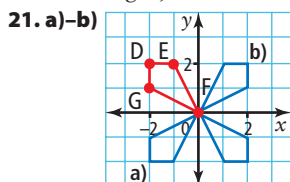

- c)** The figures have the same shape, but are located at different positions on the coordinate grid.

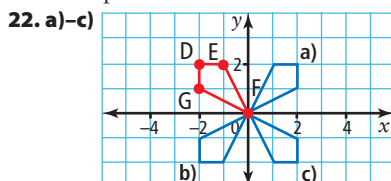

- 23.** The final designs in #21 and #22 are the same, but in quadrants I and III, the reflected vertices E and G are in opposite positions from rotated vertices E and G.

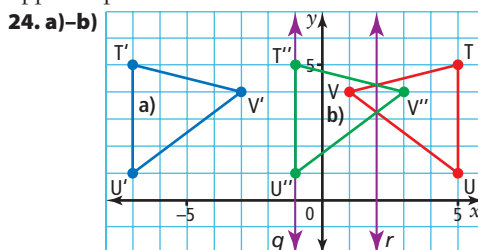

- c)** The reflection in b) has overlap and the reflection in a) does not.

- 25. a)** Answers may vary. For example, if the shape is symmetrical and moves in 1 direction only.  
**b)** Answers may vary. For example, reflect a square ABCD in quadrant I in the  $x$ -axis or translate ABCD down.  
**c)** The  $x$ -coordinates and  $y$ -coordinates of the vertices are the same.

### 1.4 Horizontal and Vertical Distances, pages 34–35

- 3. a)** 5 units horizontally right, 2 units vertically up  
**b)** 3 units vertically down  
**c)** 1 unit horizontally left, 1 unit vertically up  
**4. a)** 5 units horizontally left, 5 units vertically up  
**b)** 5 units vertically up  
**c)** 7 units horizontally right, 4 units vertically up  
**d)** 5 units horizontally left, 2 units vertically up  
**e)** 3 units horizontally right, 1 unit vertically up  
**f)** 6 units horizontally right  
**5. a)**  $K'(-5, 0)$ ,  $L'(-4, -1)$ ,  $M'(-6, -3)$   $N'(-7, -2)$   
**b)** 7 units horizontally left, 1 unit vertically down

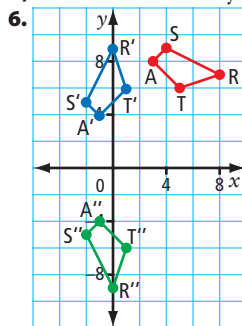

- a)**  $A''(-1, -4)$ ,  $S''(-2, -5)$ ,  $R''(0, -9)$ ,  $T''(1, -6)$   
**b)** S to  $S''$ : 6 units horizontally left, 14 units vertically down; T to  $T''$ : 4 units horizontally left, 12 units vertically down; A to  $A''$ : 4 units horizontally left, 12 units vertically down; R to  $R''$ : 8 units horizontally left, 16 units vertically down

- 7. a)** car C  
**b)** Car A is closest to the bridge (car B is equal in distance but must take a left turn, which may slow it down).  
**c)** Answers may vary. For example, 12 units horizontally right, 10 units vertically up

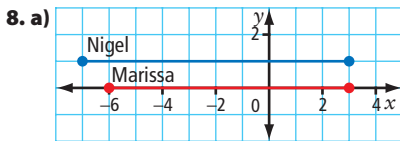

**b)** Marissa's car travelled a distance of 9 units, Nigel's car travelled a distance of 10 units. **c)** Nigel won.

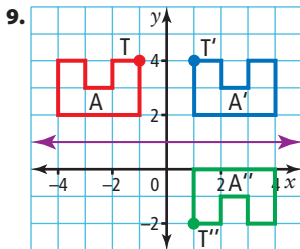

**a)** 2 units horizontally right, 6 units vertically down  
**b)** Yes. Rotate  $180^\circ$  clockwise about the point  $(0, 1)$ .  
**10. a)-b)** Answers will vary. For example,

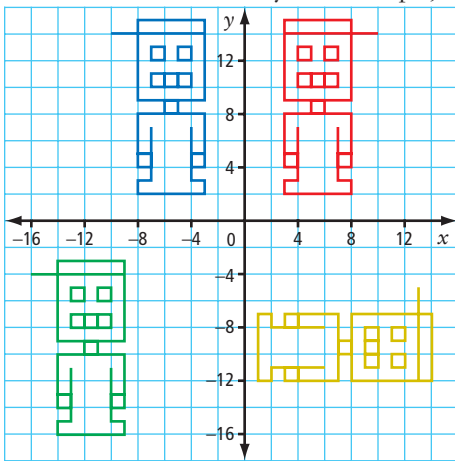

**c)** Answers may vary.

**11.** Answers may vary. For example, work with translations/reflections because it is easier to predict the resulting image.

**12.**  $C(6, -2)$

**13. a)**  $A(6, 4)$

**b)** 2 units horizontally left, 10 units vertically down

**c)** 2 units horizontally left, 2 units vertically up

**14. a)** 6 units **b)** 20

### Chapter 1 Review, pages 36–37

**1.** B

**2.** A

**3.** G

**4.** H

**5.** I

**6.** J

**7.** E

**8.** F

**9.** C

**10. a)**  $(0, 0)$  **b)**  $(-1, -3)$  **c)**  $(7, 0)$  **d)**  $(-5, 2)$

**11. a)** E, D, F **b)** B, C **c)** A, J **d)** G, H

**12. a)** B **b)** They appear to create a straight line.

**13.**  $A(0, 0)$ ,  $B(-1, 3)$ ,  $C(2, 2)$ ,  $D(1, -1)$ ,  $E(-1, -2)$

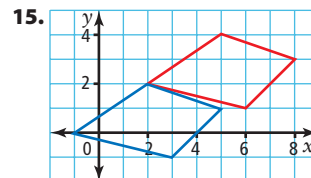
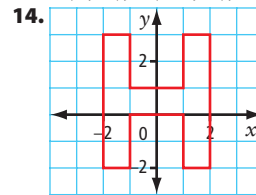

$(2, 2)$ ,  $(5, 1)$ ,  $(3, -1)$ ,  $(-1, 0)$

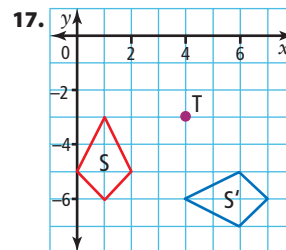
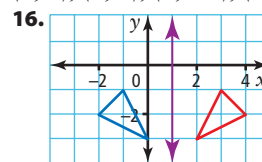

$(6, -5)$ ,  $(7, -6)$ ,  $(6, -7)$ ,  $(4, -6)$

**18. a)** 5 units vertically up

**b)** 6 units horizontally left, 6 units vertically up

**c)** 5 units horizontally left, 3 units vertically up

**d)** 6 units horizontally left

**19. a)** 8 units horizontally right, 3 units vertically down

**b)** 8 units horizontally right, 3 units vertically down

**20.** 2 units vertically up;  
 2 units vertically up;  
 4 units horizontally right,  
 2 units vertically up

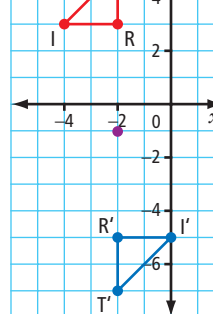

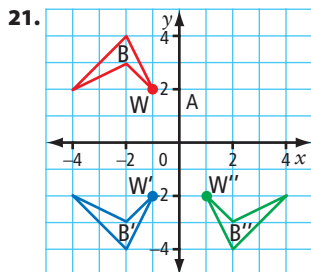

- a) 2 units horizontally right, 4 units vertically down  
 b) Yes. Rotate  $180^\circ$  clockwise about the point  $(0, 0)$ .

## Chapter 2

### 2.1 Add and Subtract Decimal Numbers, pages 48–51

4. 90.98,  $60 + 20 = 80$   
 b) 141.73,  $70 + 30 + 20 = 120$   
 c) 1751.73,  $600 + 900 + 200 = 1700$   
 5. a) 0.9770,  $0.4 + 0.3 + 0.2 = 0.9$   
 b) \$16.62,  $9 + 6 = 15$   
 c) 763.70,  $200 + 400 = 600$   
 d) 509.7,  $300 + 100 = 400$   
 6. a) 95.2,  $60 + 20 = 80$   
 b) \$95.61,  $300 - 200 = 100$   
 c) 7.596,  $4 + 2 = 6$   
 7. a) 23.11,  $30 - 5 = 25$   
 b) \$7504.55,  $3000 + 4000 = 7000$   
 c) 46.1 m,  $600 - 500 = 100$   
 8. a) 59.37 b) 163.66 c) 82.36 d) 7.16  
 9. a) 12.218 b) 2.097 c) \$262.79  
 10. a) 3.10 b) \$3.02 c) 0.212 d) \$240.29  
 11. Answers may vary. a) \$100  
 b) Lower, because used very low front-end estimate for road bike.  
 c) \$151.09  
 12. 20.32 kg  
 13. 229.88 cm  
 14. Answers may vary. i) 0.5, 0.5, 0.3, 0.7  
 ii) 0.5, 0.5, 0.5, 0.5 iii) 0.9, 0.5, 0.3, 0.3  
 15. The year before was faster by 3.48 s.  
 16. a) B higher by 0.01 m b) A faster by 0.23 s  
 c) B faster by 0.8 s d) B by 164 points  
 17. 22.16  
 18. Yes. Answers may vary. Both estimating and calculating give an answer of 0.  
 19. a) Hudson Bay, Arctic, Atlantic, Pacific  
 b) 2 million  $\text{km}^2$   
 c) 11 million  $\text{km}^2$   
 d) 9.99 million  $\text{km}^2$   
 e) Larger, the estimate was rounded up more than down.  
 20. No. Relative size:  $\$4 + \$6 + \$10 = \$20$ ,  
 but  $\$0.45 - \$0.01 - \$0.40 = \$0.04$   
 21. 7.9 kg

22. The pants were more expensive. The difference between what they started with and what was left over was greatest for George (\$56.23).

23. a) 6 b) 5 c) 6 is more accurate. In part a) only the answer was rounded. In part b) both initial values were rounded. The actual value of 5.65 is closer to 6 than to 5.

24. Answers may vary.

a)

Item	Plan 1	Plan 2
Glue stick	1	1
Coloured pencils	1	1
Calculator	1	1
Pencils	1	3
Art eraser	1	0
Ruler	1	1
3-ring notebook	1	1
Pencil case	1	1
Total:	\$24.48	\$24.59

b) \$0.11 c) Plan 1

25. a)

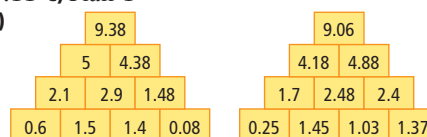

b) Find the difference between the layers. Do the lower blocks first, and the upper blocks last.

### 2.2 Multiply Decimal Numbers, pages 57–59

3. a) 82.96,  $6 \times 10 = 60$ , 60 is closer to 82.96 than to 8.296 or 829.6  
 b) 43.74,  $40 \times 1 = 40$ , 40 is closer to 43.74 than to 4.374 or 437.4  
 4. a) 41.36,  $4 \times 8 = 32$ , 32 is closer to 41.36 than to 4.136 or 413.6  
 b) 38.08,  $10 \times 3 = 30$ , 30 is closer to 39.08 than to 3.808 or 380.8  
 5. a)  $2 \times 3 = 6$ ; 5.25 b)  $10 \times 0.1 = 1$ ; 2.56  
 c)  $400 \times 2 = 800$ ; 594 d)  $14 \times 3 = 42$ ; 34.5  
 6. a)  $70 \times 3 = 210$ ; 238 b)  $4 \times 3 = 12$ ; 9.72  
 c) 27; 27 d)  $50 \times 10 = 500$ ; 391  
 7. a)  $4 \times 600 = 2400$ ; 2197.85  
 b)  $\$10 \times 500 = \$5000$ ; \$6429.10  
 c)  $7 \times 2 = 14$ ; 15.792  
 8. a)  $4 \times 200 = 800$ ; 871.06  
 b)  $3 \times 3 = 9$ ; 7.205  
 c)  $70 \times 30 = 2100$ ; 1869.67  
 9. 70.2 kg  
 10. \$7839  
 11. 176.7 km  
 12. \$308.75  
 13. a) 275.2 b) 275.2 c) 27.52 d) 2.752 e) 27.52  
 14. 300, 2 decimal places right; 30, 1 decimal place right; 3, 0 decimal places right or left; 0.1, 1 decimal place left; 0.01, 2 decimal places left; 0.003, 3 decimal places left

- 15. a)** 46.5, 3700, 580 **b)** larger  
**c)** Answers may vary. For example, when multiplying by 10, 100, 1000, move the decimal point to the right, 1, 2, or 3 places, respectively.
- 16. a)** 0.3, 0.045, 0.000345 **b)** smaller  
**c)** Answers may vary. When multiplying by 0.1, 0.01, 0.001, move the decimal point to the left, 1, 2, or 3 places, respectively.
- 17. a)** \$9.95 **b)** \$11.96
- 18. a)** 450 g, front-end estimation:  $10 \times 40 + 50 = 450$   
**b)** 601.9 g
- 19.** 1238.4 g
- 20. a)** 23.75 h **b)** \$219.69
- 21. a)** 136 cm  
**b)** Answers may vary. For example,  $10 \times 13.6 = 136$

### 2.3 Divide Decimal Numbers, pages 65–67

- 4. a)** 1.224,  $30 \div 30 = 1$ , 1 is closer to 1.224 than to 0.1224 or 12.224 **b)** 14.8,  $6 \div 0.5 = 12$ , is closer to 14.8 than to 1.48 or 148
- 5. a)** 81.0, Estimate  $60 \div 1 = 60$ , 60 is closer to 81 than to 8.1 or 810 **b)** 0.99, Estimate  $6 \div 6 = 1$ , 1 is closer to 0.99 than to 9.9 or 99
- 6. a)** 4; 3.75 **b)** 5; 5.7 **c)** 9; 8.5 **d)** 8; 7
- 7. a)** 14; 13.86 **b)** 70; 74.4 **c)** 9; 9.212 **d)** 6; 6.62
- 8. a)** 6; 5.5 **b)** 5; 4.95 **c)** 1; 0.93
- 9. a)** 3; 2.87 **b)** 8; 8.62 **c)** 80; 87.32
- 10.** \$2.57
- 11. a)** It takes about 6 jumps of 0.3 to get from 0 to 2.  
**b)**  $2 \div 0.355 \approx 5.63$  cans
- 12.**  $420 \div 70 = 6$  h;  $398.75 \div 72.5 = 5.5$  h
- 13. a)** \$0.34 **b)** \$0.50
- 14. a)** 0.03, 3, 300  
**b)** Answers may vary. If the divisor is greater than 1, move the decimal point to the left. If the divisor is less than 1, move the decimal point to the right.
- 15. a)** 0.465, 0.37, 0.00058  
**b)** smaller  
**c)** Answers may vary. For each increase in the divisor from 10 to 100 to 1000, move the decimal point 1, 2, and then 3 decimal places to the left, which is equal to the number of zeros in the divisor.
- 16. a)** 400, 145, 524  
**b)** larger  
**c)** Answers may vary. Move the decimal point in the quotient to the right according to the number of decimal places in the divisor (e.g., for 0.1, move 1 place right; for 0.01, move 2 places right).
- 17. a)** 1.2 kg **b)** 0.1 kg
- 18. a)** 0.1 mm  
**b)** Greater. The value of 51.5 was rounded to a lower value of 50 that was easier to estimate with.
- 19.** 143.6 g
- 20.** 250 sheets

- 21. a)** 73 h **b)** \$145 per hour  
**c)** Mon–Tues: \$1812.50, Wed: 0, Thurs–Sat: \$1957.50, Sun: \$1087.50
- 22. a)** 6.44 min  
**b)** 0.78 laps per min or 4.95 km/min

### 2.4 Order of Operations and Decimal Numbers, pages 71–73

- 4. a)** \$19.39  
**b)** Answers may vary. For example,  $3 \times \$4.49 + 4 \times \$0.79 + 12 \times \$0.23 = \$19.39$
- 5. a)** \$8.83  
**b)**  $5 \times \$1.09 + \$1.49 + \$1.89 = \$8.83$   
**6. a)**  $6 \times 2.5 - 0.1 \times 3 = 14.7$   
**b)**  $(4 + 1.79) \div 3 + 1.5 = 3.43$   
**c)**  $(8.1 + 3.2) \times 2 = 22.6$   
**d)**  $4.2 \div 2 - 0.5 = 1.6$
- 7. a)**  $12.4 \div 3.1 - 1.7 = 2.3$   
**b)**  $(4.5 - 1.1) \times 6.7 = 22.78$   
**c)**  $23.5 + 6.3 - 7.6 \times 2.5 = 10.8$   
**d)**  $4.1 \times (3.6 \div 0.9) + 12.4 = 28.8$
- 8. a)** Answers may vary. For example, Megan bought 3 ice cream cones for \$1.50 each for herself and 2 friends. She had 2 discount coupons worth \$1.25 each. How much did she have to pay?  
**b)** \$2.00  
**9. a)** 3.2 **b)** 2.1 **c)** 0.7  
**10.**  $0.5 + 1 - 5 \times 0.1 = 1$   
**11.** 20 h  
**12.** 1096.2 km  
**13.** \$34.95  
**14. a)** \$440 **b)**  $(80 \times 3.25) + (120 \times 1.5) = 440$   
**c)** \$280 **d)** \$160
- 15.** Answers may vary. **a)** \$12.00 **b)** \$11.35
- 16. a)** Mars  $687 \div 365 = 1.88$   
**b)** 11.87 years  
**c)** 4.149 times  
**d)** Use a number line with jumps of about 0.24 years to show about 4 orbits in 1 Earth year.
- 17. a)** \$31.5 billion U.S.  
**b)** \$15.0 billion U.S.  
**c)** 7.04 times as great as  
**18. a)**  $(7 + 30) \times 0.5 = 18.5$   
**b)**  $(6 + 3) \times 0.2 + 0.4 \div (2 - 1) = 2.2$   
**19. a)**  $(80 \div 0.4) + (6 \times 0.3) = 201.8$   
**b)**  $80 \div (0.4 + 6) \times 0.3 = 3.75$   
**20. a)** 656  
**b)** Answers may vary. For example, \$110 000
- 21. a)** Cecil: \$8.99, Kent: \$8.09, Laura: \$6.09  
**b)** \$23.17  
**c)** Calculate individual totals, then add individual totals.
- 22. a)** 3.5 kg **b)** 14 days



23.

Name	Hours	Hourly Wage	Total Wage
Jeanne	45	\$10.50	\$472.50
Alice	42	\$17.00	\$714.00
Fatek	18	\$7.75	\$139.50
Larry	50	\$15.25	\$762.50

24. 57.8 mm

### Chapter 2 Review, pages 74–75

- D
- B
- C
- A
- a) 98.48, relative size estimate:  $1 + 10 + 1 + 90 = 102$ , 102 is closer to 98.48 than to 9.848 or 984.8

b) 278.63, relative size estimate:  $400 - 100 = 300$ , 300 is closer to 278.63 than to 27.863 or 278.3

c) 34.073, relative size estimate:  $30 + 10 - 10 = 30$ , 30 is closer to 34.073 than to 3.4073 or 340.73
- a) 6; 6.95 b) 5; 4.7 c) 8; 8.86

d) 6; 5.62 e) 2; 2.1 f) 3; 2.777
- a) 38.95 b) 747.455 c) 56.08
- 85.95 kg
- a) 6.75 b) 8.0370 c) 1888.48
- relative size estimate: 8, 7.56 is closer to 8, 0.7 is closer to 1, 5.3
- 5.7 kg
- \$532.95
- a) 71.00, about 70 steps of 0.4 between 0 and 28, 70 is closer to 71.00 than to 7.100 or 710.0

b) 5.3, relative size estimate:  $40 \div 8 = 5$ , 5 is closer to 5.30 than to 0.530 or 530

c) 27.04, relative size estimate:  $250 \div 10 = 25$ , 25 is closer to 27.04 than to 2.704 or 270.4
- a) 58; 54.45 b) 35; 36.9 c) 20; 23.8
- 2.05 m
- 30.4 mm
- a) 2.7 b) 35.21 c) 22.3
- a)  $3.6 + 8.2 \div 4 = 5.65$

b)  $4.9 - 7.2 \times 0.1 = 4.18$

c)  $62.32 \div (10.1 - 2.5) = 8.2$
- a)  $(7.5 + 8.6) \times 9.1 = 146.51$

b)  $45.15 \div (0.8 + 1.7) \times 2.2 = 39.732$

c)  $(12.6 - 3.3) \div 3 + 11.4 = 14.5$
- a) \$1560.00

b)  $(80 \times 12.5) + (30 \times 8.25) + (50 \times 6.25)$

## Chapter 3

### 3.1 Parallel and Perpendicular Line Segments, pages 87–88

- Parallel: CD and EF, EF and GH, CD and GH.

Perpendicular: AB and CD, AB and EF, AB and GH, AH and GH, AH and CD, AH and EF.
- Parallel: Main and North, Major and Centre.

Perpendicular: Main and Major, Main and Centre, North and Major, North and Centre

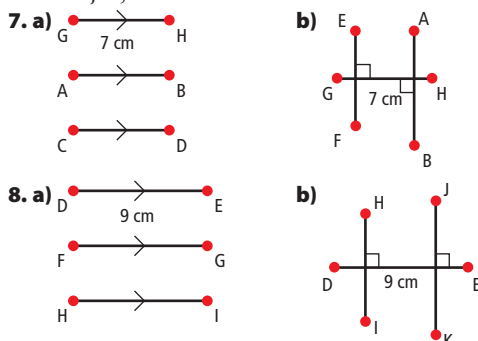

- Parallel. Answers may vary. A biplane has 2 sets of wings, which are the same distance apart at any two points.
- Yes. Measure the distance between each pair of lines at either end with a ruler.
- Answers may vary.
- a) lines painted in the middle of a road, railroad tracks

b) side and bottom of a box, window frame

c) playing card, table
- Check that only parallel and perpendicular line segments have been used.
- Answers may vary. From each end of the existing shelf, measure and mark an equal distance away. Connect the marks with a line.

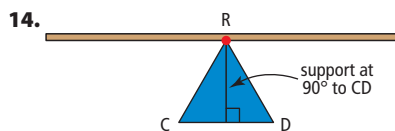

- a) Answers may vary. Angles 1, 4, 5, and 8 are equal, and angles 2, 3, 6, and 7 are equal.

b) There are only 2 different sizes of angles.

### 3.2 Draw Perpendicular Bisectors, pages 92–93

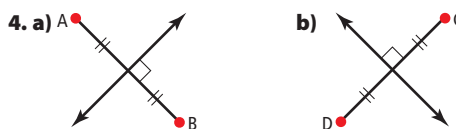

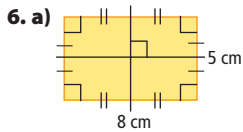
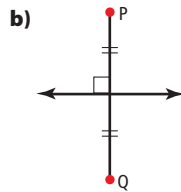
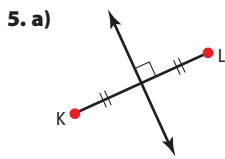

b) The lines intersect at the centre of the rectangle.

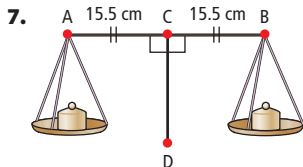

8. Answers may vary. **i)** Measure AD. Extend AD to point B so that  $AD = DB$ . **ii)** Make your compass opening equal AD. With your compass point at D, draw an arc equal in length to AD. To draw DB, extend AD until it intersects the arc.

9. Cut a support post that is 1.4 m high. To find the halfway point of the top horizontal pole, divide the length of 3 m in half to get 1.5 m. Place the support at this halfway point. Measure a right angle where the top pole and the support meet in order to position the support perpendicular to the top pole.

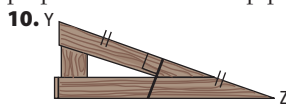

Answers may vary slightly. 0.25 m

### 3.3 Draw Angle Bisectors, pages 98–99

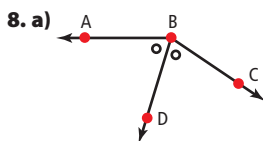
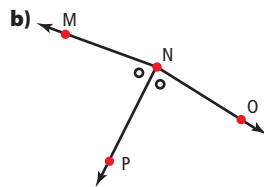
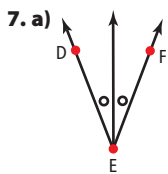
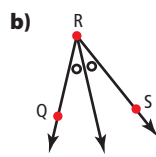
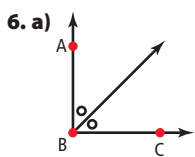

b) Answers may vary.

c)  $\angle ABD = 73^\circ$ ,  $\angle CBD = 73^\circ$

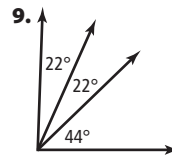

10. Methods used may vary.

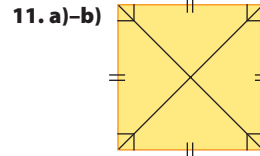
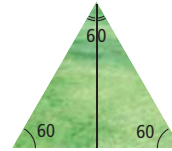

c) Answers may vary. The bisectors meet in the centre of the square and the resulting angles are all equal.

12. The triangle is an equilateral or an isosceles triangle because at least two angles are equal. If the parents bisect the angle in the river, they will divide the land into 2 equal pieces.

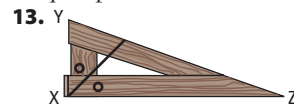

Answers may vary slightly. 0.5 m.

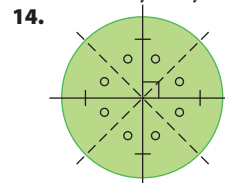

Draw a line that divides the circle in half and draw the perpendicular bisector of that line. Then draw the angle bisector of the 4 resulting right angles.

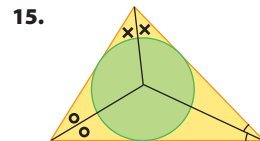

a) They meet inside the triangle.

b) The circle touches all 3 sides.

### 3.4 Area of a Parallelogram, pages 105–107

3. a)  $3 \text{ cm}^2$  b)  $6 \text{ cm}^2$

4. a)  $4 \text{ cm}^2$  b)  $9 \text{ cm}^2$

5. a)  $20 \text{ cm}^2$  b)  $21 \text{ cm}^2$

6. a)  $24 \text{ cm}^2$  b)  $8 \text{ cm}^2$

7. a)  $55 \text{ cm}^2$  b)  $63 \text{ cm}^2$  c)  $18.6 \text{ m}^2$

8. a)  $27 \text{ m}^2$  b)  $113.16 \text{ mm}^2$  c)  $40.5 \text{ cm}^2$

9. 4 m

10. 6 m



**11. a)** Answers may vary.  $b = 2$  cm,  $h = 1.5$  cm. Measure the base using a ruler. Use a protractor to draw the height perpendicular to the base and measure the height using a ruler. **b)**  $3$  cm<sup>2</sup> **c)** The answer is the same.

**12.** They are equal in area. The base and height of the 2 shapes are the same.

**13.** 2 m

**14.**  $10$  cm<sup>2</sup>

**15.** 28 units<sup>2</sup>

**16.**  $10.8$  cm<sup>2</sup>

**17.** 27 000 m<sup>2</sup>

**18. a)**  $95$  m<sup>2</sup> **b)**  $\$50 \times 100 = \$5000$  **c)**  $\$5225$

**19.** 9.6 cm

**20.** Answers may vary. 16.05 cm<sup>2</sup>  
Divide the X into 3 sections. Use a ruler to measure the base and height of parallelogram 1, parallelogram 2, and parallelogram 3. Calculate the area of each. The area of the X is area 1 + area 2 - area 3.



### 3.5 Area of a Triangle, pages 113–115

**4. a)**  $3$  cm<sup>2</sup> **b)**  $2$  cm<sup>2</sup>

**5. a)**  $6$  cm<sup>2</sup> **b)**  $4$  cm<sup>2</sup>

**6. a)**  $21$  cm<sup>2</sup> **b)**  $10$  cm<sup>2</sup>

**7. a)**  $8$  cm<sup>2</sup> **b)**  $7.5$  cm<sup>2</sup>

**8. a)**  $27$  mm<sup>2</sup> **b)**  $40$  cm<sup>2</sup> **c)**  $86.14$  mm<sup>2</sup>

**9. a)**  $14.4$  m<sup>2</sup> **b)**  $19.36$  cm<sup>2</sup> **c)**  $0.54$  m<sup>2</sup> or  $5400$  cm<sup>2</sup>

**10.** 78 daffodils

**11.** 4 bags

**12.** Answers may vary.

**a)**  $b = 3.5$  cm,  $h = 2$  cm

**b)** Measure the height and base at right angles with a ruler. **c)**  $3.5$  cm<sup>2</sup>

**13.** Answers may vary.

**a)**  $b = 3.5$  cm,  $h = 1.2$  cm. Measure the base using a ruler. Use a protractor to draw the height perpendicular to the base and measure the height using a ruler.

**b)**  $2.1$  cm<sup>2</sup>

**c)** It is the same.

**14. a)**  $269.15$  m<sup>2</sup>

**b)** Yes. Answers may vary. You will need additional material for the seams and attachments.

**15.**  $0.3$  m<sup>2</sup>

**16.** No, they do not have the same perimeter.

**17.**  $26.28$  cm<sup>2</sup>

**18.** Emily. Answers may vary. When a triangle and parallelogram have the same base and the same height, the area of the triangle is 50% of the area of a parallelogram. This triangle has half the height of the parallelogram, so it has 25% of the area of the parallelogram.

**19.** Fahad is correct. Answers may vary. For example,

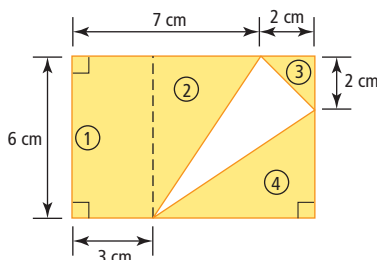

$$\begin{aligned} \text{Area of white triangle} &= \text{Area of rectangle} - (\text{area1} + \text{area2} + \text{area3} + \text{area4}) \\ &= (9 \times 6) - (3 \times 6 + \frac{4 \times 6}{2} + \frac{2 \times 2}{2} + \frac{6 \times 4}{2}) \\ &= 54 - (18 + 12 + 2 + 12) \\ &= 10 \text{ cm}^2 \end{aligned}$$

### Chapter 3 Review, pages 116–117

**1.** D

**2.** E

**3.** F

**4.** B

**5.** C

**6. a)** parallel **b)** neither **c)** perpendicular **d)** neither

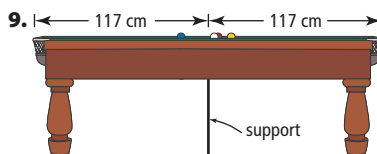
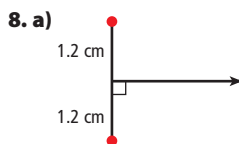
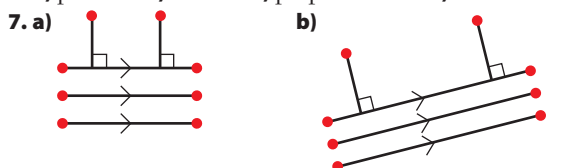

**10. a)** 7.5 cm **b)**  $\frac{1}{4}$  of the original line segment



**12. a)** Answers may vary.  $66^\circ$

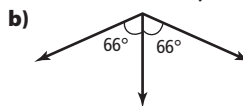

**13. a)**  $20^\circ$  **b)**  $\frac{1}{4}$  of the original angle

**14. a)**  $15$  m<sup>2</sup> **b)**  $19.98$  mm<sup>2</sup>

15. The area of the rectangle is 2.7 times the area of the parallelogram. The only difference is the length of the base. The height is the same.

16. a)  $6 \text{ m}^2$  b)  $13.78 \text{ m}^2$

17. a)  $0.88 \text{ km}^2$  b) The creek is not in a straight line.

## Chapter 4

### 4.1 Connect Fractions, Decimals, and Percents, pages 129–131

5. a) 67 marbles b) 23 cookies c) \$37.40 d) 32.7 m

6. a) 17 daffodils b) 1.8 cm c) 10.5 min d) \$0.14

7. a) 1.5 min b) 3.4 cm c) 5 cats d) \$8.95

8. Answers may vary. a) 50% of 44 is 22.

b) 50% of 20 is 10, so 25% of 20 is 5.

c) 10% of 12 is 1.2. d) 1% of 150 is 1.5.

9. Answers may vary. a) 50% of \$40 is \$20, 10% of \$40 is \$4, so 60% of \$40 is  $\$20 + \$4 = \$24$ .

b) 50% of 44 is 22, 25% of 44 is 11, so 75% of 44 is  $22 + 11 = 33$ .

c) 10% of 750 is 75, so 20% of 750 is  $75 + 75 = 150$ .

d) 25% of 240 is 60, 10% of 240 is 24, so 35% of 240 is  $60 + 24 = 84$ .

10. Answers may vary. a) 50% of \$60 is \$30, 25% of \$60 is \$15, so 75% of \$60 is  $\$30 + \$15 = \$45$ .

b) 25% of 120 m is 30 m, 10% of 120 m is 12 m, so 35% of 120 m is  $30 \text{ m} + 12 \text{ m} = 42 \text{ m}$ .

c) 50% of 280 students is 140 students, 25% of 280 students is 70 students, 10% of 280 students is 28 students, so 85% of 280 students is  $140 + 70 + 28 = 238$  students.

d) 10% of 45 cm is 4.5 cm, so 30% of 450 cm is  $4.5 \text{ cm} + 4.5 \text{ cm} + 4.5 \text{ cm} = 13.5 \text{ cm}$ .

11. Answers may vary. 50% of 68 is 34, 25% of 68 is 17, 75% of 68 is 51, 37.5% is half of 75%, and half of 51% is 25.5.

12. a) 0.57 b) 0.3 c) 0.05 d) 0.88

13. a) 0.42 b) 0.38 c) 0.15 d) 0.73

14. a)  $\frac{1}{10} < 0.12 < 14\%$  b)  $0.24 < \frac{1}{4} < 27\%$

c)  $0.39 < 40\% < \frac{41}{100}$

15. a)  $0.35 > 32\% > \frac{3}{10}$  b)  $76\% > \frac{3}{4} > 0.72$

c)  $0.54 > \frac{1}{2} > 45\%$

16. Answers may vary. a)  $\frac{3}{10}$  b) 0.15 c) 0.8

17. a) 31 b)  $\frac{7}{8}$

18. Answers may vary. 1.6

19. Answers may vary. Move the decimal point for the price of the item 1 decimal place to the left.

20. 62 300

21. Answers may vary. 10% of \$28 = \$2.80, 5% of \$28 = \$1.40,  $\$2.80 + \$1.40 = \$4.20$

22. 294 students

23. 68.2 kg

24. a) 27 cm b) 135 cm

25. \$360.75

26.  $0.41 > \frac{4}{10} > 37\frac{1}{2}\% > \frac{1}{4}$

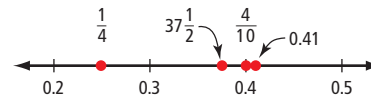

27. 1440 females

28. 1300 seats

29. 30%

30. a) Junior \$0.47, Jumbo \$0.80, Kong \$1.19

b) Junior \$3.03, Jumbo \$3.70, Kong \$4.31

c) \$1684.60

### 4.2 Fractions, Decimals, and Percents, pages 137–139

5. a) 0.5 b) 0.50 c) 0.9 d) 0.682

6. a) 0.4 b) 0.611 c) 0.72 d) 0.061

7. a) Player A: .321, Player B: .316

b) Player A: He gets a hit over 32% of the time he is at bat. Player B's average is under 32%.

8. a)  $0.\overline{5}$  b)  $0.\overline{09}$  c)  $0.\overline{187}$  d)  $2.\overline{015}$

9. a)  $0.\overline{4}$  b)  $0.\overline{26}$  c)  $0.\overline{185}$  d)  $1.\overline{062}$

10. a)  $0.8333333\overline{3}$ ,  $0.8\overline{3}$

b)  $0.6666666\overline{6}$ ,  $0.\overline{6}$

c)  $0.454545454\overline{5}$ ,  $0.\overline{45}$

d)  $0.636363636\overline{3}$ ,  $0.\overline{63}$

11. a)  $0.16666666\overline{6}$ ,  $0.1\overline{6}$

b)  $0.428571428\overline{5}$ ,  $0.4\overline{28571}$

c)  $0.25252525\overline{2}$ ,  $0.\overline{25}$

d)  $0.36363636\overline{3}$ ,  $0.\overline{36}$

12. a) between 50% and 60%, but closer to 50%

b) between 40% and 50%, but closer to 40%

13. a) 55% b) between 50% and 60%, but closer to 50%

14. a)  $\frac{95}{100}$  b)  $\frac{3}{10}$  c)  $\frac{243}{1000}$  d)  $\frac{8}{100}$

15. a)  $\frac{80}{100}$  b)  $\frac{2}{10}$  c)  $\frac{18}{100}$  d)  $\frac{455}{1000}$

16. a)  $\frac{5}{100}$  or  $\frac{1}{20}$ ,  $\frac{10}{100}$  or  $\frac{1}{10}$ ,  $\frac{25}{100}$  or  $\frac{1}{4}$

b) 0.05, 0.1, 0.25

c) A nickel is 5% of a dollar. A dime is 10% of a dollar. A quarter is 25% of a dollar.

17. a)  $\frac{71}{100}$  b)  $\frac{421}{1000}$  c)  $\frac{78}{100}$

18. a) between 55% and 60%, but closer to 60%

b) There are 140 children in the daycare. 50% of 140 is 70, 10% of 140 is 14, 5% of 140 is 7.

$55\% = 70 + 7 = 77$  (too low)

$60\% = 70 + 14 = 84$  (too high)

81 is closer to 84 than 77. The percent of the children in the daycare that are girls is closer to 60%.

19. a) between 30% and 40%, but closer to 30%

b)  $\frac{85}{270}$ , 0.315 c) 31.5%; This is close to the estimate.

20. a)  $0.\overline{4}$  b)  $0.\overline{8}$

21. a)  $\frac{3}{11}, \frac{10}{11}, \frac{9}{11}$

b) Answers may vary. The digits that repeat add to 9. Convert the decimal number to a fraction where the denominator is 11 and the numerator is one number larger than the first number of the repeating pattern.

c) 0.090909..., 0.181818..., 0.454545..., 0.72727272...

22. a) 0.142857, 0.285714, 0.428571, 0.571428, 0.714285, 0.857142

b)  $142 + 857 = 999$ ,  $285 + 714 = 999$ ,  
 $428 + 571 = 999$ ,  $571 + 428 = 999$ ,  $714 + 285 = 999$ ,  
 $857 + 142 = 999$

c) When the numbers in the first half of each repeating pattern are added to the numbers in the last half of each repeating pattern, the sum is 999.

d) For the decimal equivalent of  $\frac{7}{13}$ , the sum of the numbers in the first half of the repeating pattern and the last half of the repeating pattern is 999. For the decimal equivalent of  $\frac{4}{11}$ , the sum of the numbers in the first half of the repeating pattern and the last half of the repeating pattern is 9.

#### 4.3 Applications of Percents, pages 143–145

4. a) 50% of 184, 92, 52

b) 10% of 640, 64, 3.25

c) 35% of 140, 49, 42

5. a) \$54.00 b) \$135.00 c) \$540.00

d) The answer in c) is 4 times larger than the answer in b).

6. The second group of eggs was better (i.e., approximately 56% hatched).

7. The second order of books had the greater percent of adventure novels (i.e., approximately 43% were adventure novels).

8. Tuesday (i.e., approximately 90% of the people signed out books).

9. a) Roast turkey: 21.4%, Ground beef: 21.1%, Almonds: 22.2%, Tuna: 21.3%

b) Almonds, Roast turkey, Tuna, Ground beef

10. The discount is \$248. The new price is \$992.

11. a) Answers will vary. \$70.00

b) \$70.00

c) \$129.99

12. a) Adults: \$2.19, Students: \$1.61

b) Yes. Answers may vary. It would be easier to make change.

c) Adults: \$2.20, Students: \$1.60

13. a) \$3458.74 b) \$44 149.74

14. a) Carl b) Meagan: 14.3%, Carl: 12.0%, Billi: 10.1%

c) Meagan

15. a) 76% b) Answers may vary. 56%

16. a) 30% b) 30.2% c) 53.1% d) 34.5%

17. Answers may vary. a) \$39.00 b) \$41.00

18. a) 10%, 0.1,  $\frac{1}{10}$ , 50%, 0.50,  $\frac{1}{2}$ , 25%, 0.25,  $\frac{1}{4}$ , 75%, 0.75,  $\frac{3}{4}$

b) Winnipeg: 90%, Churchill: 50%, Rankin Inlet: 75%, Baker Lake 25%

19. 180

20. a) 128 b) 160

21. \$55 000

22. 40%

#### Chapter 4 Review, pages 146–147

1. B

2. D

3. C

4. a) 2.5 b) 21 c) 49 d) 93

5. a)  $\frac{1}{8}$  b) 75% c) 1.25

6. Answers may vary.  $\frac{3}{4}$ , 76%,  $0.\bar{7}$ ; 0.75, 0.76, 0.777777...

7. Answers may vary. 39.1 is between 39 and 40, but closer to 39.

8. Answers will vary. 10% of 180 is 18, so 40% of 180 is  $4 \times 18 = 72$ .

9. a) \$19.56 b) \$52.16

10. a)  $\frac{1}{4}$ , 0.25, 25% b)  $\frac{75}{100}$ , 0.75, 75% c)  $\frac{20}{100}$ , 0.20, 20%

d)  $\frac{5}{100}$  or  $\frac{1}{20}$ , 0.05, 5% e)  $\frac{35}{100}$ , 0.35, 35%

11. 37.5%

12. a)  $0.8\bar{3}$ , repeating b) 0.75, terminating c)  $0.\bar{4}$ , repeating

13. a) 0.66 b) 0.5 c) 0.512 d) 0.2

14. a) Answers may vary. 73%

b) Round 86 to 90.  $\frac{90}{120}$  is 75%. 86 is less than 90, so the percent is less than 75%.

c) 71.7%

15. a)  $\frac{8}{10}$  b)  $\frac{35}{100}$  c)  $\frac{167}{1000}$

16. a) Answers may vary. 33%, 472 is close to 500, 1595 is close to 1500.  $\frac{500}{1500}$  is approximately 33%,

b) 23.8% c) 45.5%

17. Jason Maas: 67.1%, Ricky Ray: 65.9%; Jason Maas has a better passing statistic.

18. Becky. Catriona's save percentage is  $\frac{654}{680} = 96.2\%$ ,

Becky's save percentage is  $\frac{532}{548} = 97.1\%$ ; Becky has a better save percentage.

19. 28.97%

20. a) \$14.50 b) \$43.50

21. 4.8 h

Chapters 1–4 Review, pages 152–154

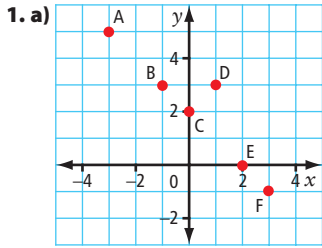

1. a) **b)** D(1, 3) **c)** G(-2, 4), H(1, 1)  
**2.** D(2, -2), E(2, 2), F(-2, 2), G(-2, -2)  
**3.** (5, -3)  
**4. a)** reflection **b)** translation **c)** rotation  
**5. a)** A'(0, 0), B'(0, -4), C'(4, 0)  
**b)** A''(0, 0), B''(0, -4), C''(-4, 0)  
**c)** 4 units horizontally left, 4 units vertically down  
**6. a)** T'''(-1, 2), E'''(2, 2), A'''(2, -1), M'''(-1, -1)  
**b)** 4 units horizontally right, 9 units vertically up  
**7. a)** 0.9770 **b)** 20.66 **c)** 18.7898 **d)** 1.992  
**8. a)** 7; 7.85 **b)** 7; 6.8 **c)** 12; 9.62 **d)** 4; 5.8  
**9. a)** 3.2 **b)** 19.7  
**10.** \$194.75  
**11. a)** Answers may vary. \$36.00 **b)** \$34.90  
**c), d)** Answers will vary by province or territory.  
**12. a)** approximately 15 cans, 14 cans will not be enough  
**b)** approximately 42 students  
**c)** \$27.45  
**d)** Answers may vary. All bowls are filled with exactly 190 mL of soup.  
**e)** Answers may vary. The costs of purchasing plastic spoons, bowls, and serviettes.

**13.** and **14.** Constructions will vary.

**15. a)** 24 cm<sup>2</sup> **b)** 12 cm<sup>2</sup>

**16. a)** 2700 cm<sup>2</sup> **b)** 2700 cm<sup>2</sup>

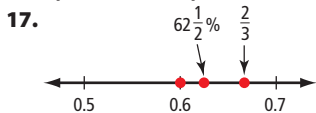

**18. a)** 0.4 **b)** 0.27 **c)** 0.285714

**19. a)**  $\frac{35}{100}$  **b)**  $\frac{2}{10}$  **c)**  $\frac{25}{1000}$

**20. a)** Electro-Zip:  $\frac{15}{20}$ , 75%; Ultraback:  $\frac{7}{10}$ , 70%;

A-Retrieve:  $\frac{23}{30}$ , 77%

**b)** A-Retrieve, fewer CD-ROMs are defective. A-Retrieve has the highest percent of CD-ROMs that passes the test for defects.

**21. a)** Maria. She sold 221 newspapers. **b)** Jeremy, 88%

**22. a)** Answers will vary. Blue is easiest to hit because it covers a wider single area than red or yellow.

**b)** blue:  $\frac{9}{25}$ , 36%; yellow:  $\frac{12}{25}$ , 48%; red:  $\frac{4}{25}$ , 16%

**c)** yellow, blue, red

Chapter 5

5.1 Probability, pages 163–164

**3. a)**  $\frac{1}{4}$ , 1:4, 25% **b)**  $\frac{2}{5}$ , 2:5, 40%

**c)**  $\frac{0}{3}$ , 0:3, 0% **d)**  $\frac{6}{6}$ , 6:6, 100%

**4. a)** 3 **b)**  $\frac{2}{3}$ , 2:3, 66.7%

**5. a)**  $\frac{3}{8}$ , 3:8, 37.5% **b)**  $\frac{4}{8}$ , 4:8, 50% **c)**  $\frac{7}{8}$ , 7:8, 87.5%

**6. a)**  $\frac{3}{9}$ , 3:9, 33.3% **b)**  $\frac{1}{9}$ , 1:9, 11.1% **c)**  $\frac{7}{9}$ , 7:9, 77.8%

**7. a)**  $\frac{3}{5}$  or 60% **b)**  $\frac{4}{5}$  or 80%

**8. a)**  $\frac{7}{20}$ , 0.35 **b)**  $\frac{3}{20}$ , 0.15

**9. a)**  $\frac{1}{20}$ , 0.05, or 5% **b)**  $\frac{10}{20}$ , 0.5, or 50% **c)**  $\frac{4}{20}$ , 0.2, or 20%

**10.**  $\frac{3}{4}$

**11.**  $\frac{5}{60}$  or 0.08 or  $8\frac{1}{3}\%$ . Answers may vary. There are 5 s between the 12 and 1. There are 60 s in 1 min.

**12.** Answers may vary. In order to be guaranteed of having at least 1 of each colour, you would have to select all the marbles.

5.2 Organize Outcomes, pages 169–170

**4. a)–b)**

		Spin		
		Tiger	Bear	Monkey
Tile Choice	Hungry	hungry, tiger	hungry, bear	hungry, monkey
	Sleepy	sleepy, tiger	sleepy, bear	sleepy, monkey
	Playful	playful, tiger	playful, bear	playful, monkey
	Angry	angry, tiger	angry, bear	angry, monkey

**c)** Yes. Choosing a tile has no effect on the spin.

**5. a)–b)**

		Card				
		Moon	Sun	Cloud	Star	Rainbow
Colour	Black (B)	B, Moon	B, Sun	B, Cloud	B, Star	B, Rainbow
	White (W)	W, Moon	W, Sun	W, Cloud	W, Star	W, Rainbow

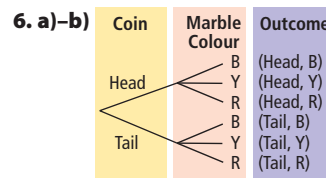

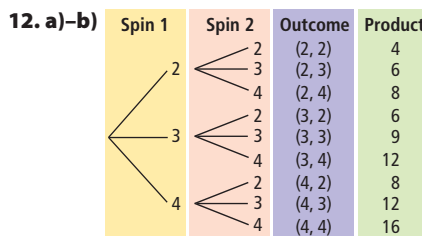
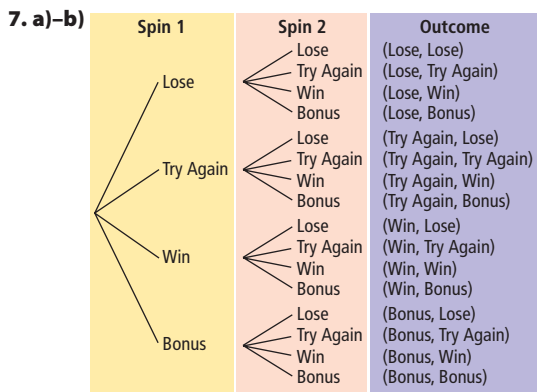

**c)**  $\frac{1}{9}$  or 11.1%

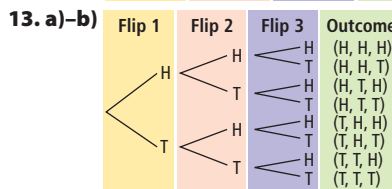

**c)** Answers may vary.

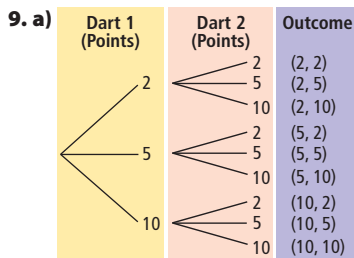
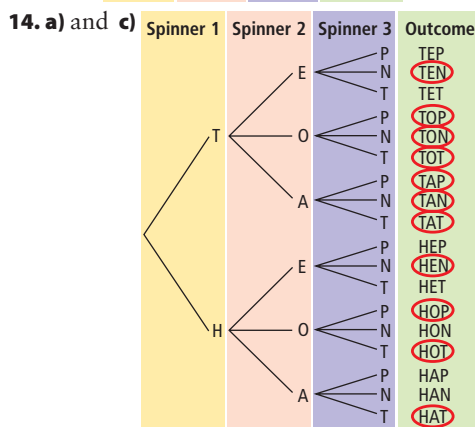
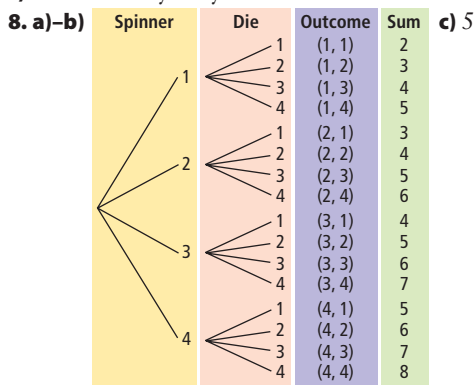

**b)** Answers will vary.

### 5.3 Probabilities of Simple Independent Events, pages 175–176

**b)** No. Answers may vary. The numbered areas are not equal in size.

**10. a)** (juice, chicken), (juice, beef), (juice, vegetarian), (milk, chicken), (milk, beef), (milk, vegetarian)

**b)** Answers may vary.

		Taco		
		Chicken (C)	Beef (B)	Vegetarian (V)
Drink	Juice (J)	J, C	J, B	J, V
	Milk (M)	M, C	M, B	M, V

**11.** Answers may vary. Spin a spinner that is divided into 3 sections labelled A, B, and C, and then roll a 4-sided die numbered 1, 2, 3, and 4.

**3. a)** **b)**  $\frac{1}{20}$  or 5%

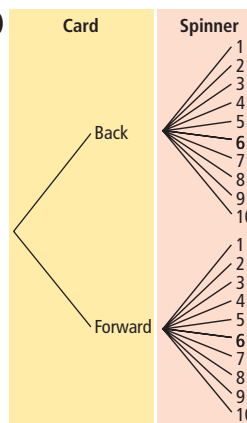

**4. a)** **b)**  $\frac{2}{8}$  or 25%

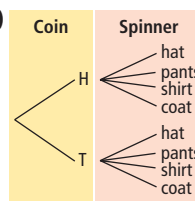

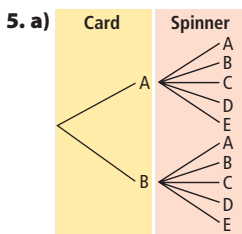

b) 10 c)  $\frac{1}{10}$  or 10%

6. a)

		Spinner				
		1	2	3	4	5
Marble	Purple	purple, 1	purple, 2	purple, 3	purple, 4	purple, 5
	Black	black, 1	black, 2	black, 3	black, 4	black, 5
	Yellow	yellow, 1	yellow, 2	yellow, 3	yellow, 4	yellow, 5
	Green	green, 1	green, 2	green, 3	green, 4	green, 5
	Red	red, 1	red, 2	red, 3	red, 4	red, 5

b)  $\frac{1}{25}$  or 4% c)  $\frac{2}{25}$  or 8% d)  $\frac{2}{25}$  or 8%

7. a)

		Spinner			
		Glass	Feather	Mirror	Stone
Block	Red	red, glass	red, feather	red, mirror	red, stone
	Green	green, glass	green, feather	green, mirror	green, stone
	Yellow	yellow, glass	yellow, feather	yellow, mirror	yellow, stone
	Black	black, glass	black, feather	black, mirror	black, stone
	Blue	blue, glass	blue, feather	blue, mirror	blue, stone

b)  $\frac{1}{20}$  or 5% c)  $\frac{4}{20}$  or 20%

8. a) Answers will vary. For example, make a tree diagram or draw a table.

b)  $\frac{1}{10}$  or 10%

9. a)

		Die					
		1	2	3	4	5	6
Coin Flip	Heads (H)	H, 1	H, 2	H, 3	H, 4	H, 5	H, 6
	Tails (T)	T, 1	T, 2	T, 3	T, 4	T, 5	T, 6

b)  $\frac{1}{12}$  or 8.3% c)  $\frac{4}{12}$  or 33.3%

10. Answers may vary. For example,

i) Flip a coin, then roll a 4-sided die.

ii) Flip a coin, then select a tile from a bag where there are 4 tiles, numbered 1, 2, 3, and 4.

11. a)

		Card 2	
		Black (B)	White (W)
Card 1	Black (B)	B, B	B, W
	White (W)	W, B	W, W

b)  $\frac{1}{4}$  or 25% c)  $\frac{1}{2}$  or 50%

12. a)–b)

		Die 2					
		Raven (r)	Osprey (o)	Eagle (e)	Hawk (h)	Falcon (f)	Crow (c)
Die 1	Raven (r)	r, r	r, o	r, e	r, h	r, f	r, c
	Osprey (o)	o, r	o, o	o, e	o, h	o, f	o, c
	Eagle (e)	e, r	e, o	e, e	e, h	e, f	e, c
	Hawk (h)	h, r	h, o	h, e	h, h	h, f	h, c
	Falcon (f)	f, r	f, o	f, e	f, h	f, f	f, c
	Crow (c)	c, r	c, o	c, e	c, h	c, f	c, c

c)  $\frac{2}{36}$  or 5.6% d)  $\frac{1}{36}$  or 2.8% e)  $\frac{36}{36}$  or 100%

13. a)  $\frac{1}{2}$  or 50% b)  $\frac{1}{4}$  or 25%

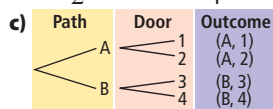

d) 0; The mouse cannot reach door 3 from path A.

14. a) Answers will vary. One of the spinners has 4 equal divisions with the following sections: volleyball, basketball, softball, and football. The other spinner has 3 equal divisions with the following sections: floor hockey, dodge ball, and trampoline.

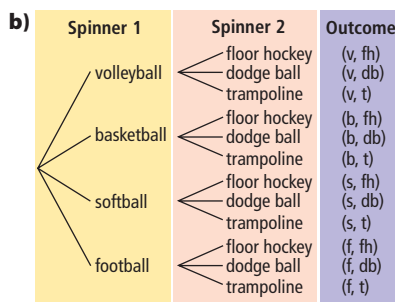

c)  $\frac{1}{12}$  or 8.3% d)  $\frac{12}{12}$  or 100% e)  $\frac{4}{12}$  or 33.3%

15. a) (0, 1), (0, 3), (0, 5), (0, 7), (0, 9), (2, 1), (2, 3), (2, 5), (2, 7), (2, 9), (4, 1), (4, 3), (4, 5), (4, 7), (4, 9), (6, 1), (6, 3), (6, 5), (6, 7), (6, 9), (8, 1), (8, 3), (8, 5), (8, 7), (8, 9)

b)  $\frac{1}{25}$  or 4%

c) (6, 1), (6, 3), (6, 5), (6, 7), (6, 9), (8, 1), (8, 3), (8, 5), (8, 7), (8, 9);  $\frac{1}{10}$  or 10%



### 5.4 Applications of Independent Events, pages 181–182

3. a)  b)  $\frac{2}{16}$  or 12.5%

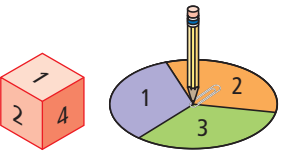
4. a)  b)  $\frac{1}{18}$  or 5.6%

5. a)

		Die			
		Eat	Work	Play	Sleep
Spinner	Morning (M)	M, eat	M, work	M, play	M, sleep
	Afternoon (A)	A, eat	A, work	A, play	A, sleep
	Evening (E)	E, eat	E, work	E, play	E, sleep

b)  $\frac{1}{12}$  or 8.3% c)  $\frac{2}{12}$  or 16.7%

6. a)

		Card			
		2	3	4	5
Die	1	1, 2	1, 3	1, 4	1, 5
	2	2, 2	2, 3	2, 4	2, 5
	3	3, 2	3, 3	3, 4	3, 5
	4	4, 2	4, 3	4, 4	4, 5
	5	5, 2	5, 3	5, 4	5, 5
	6	6, 2	6, 3	6, 4	6, 5

b)  $\frac{4}{24}$  or 16.7% c)  $\frac{6}{24}$  or 25%

7. a)  b)  $\frac{1}{18}$  or 5.6%

c)  $\frac{3}{18}$  or 16.7%

8. a)

		Throw 2				
		2	2	3	3	5
Throw 1	2	2, 2	2, 2	2, 3	2, 3	2, 5
	2	2, 2	2, 2	2, 3	2, 3	2, 5
	3	3, 2	3, 2	3, 3	3, 3	3, 5
	3	3, 2	3, 2	3, 3	3, 3	3, 5
	5	5, 2	5, 2	5, 3	5, 3	5, 5

b)  $\frac{9}{25}$  or 36% c)  $\frac{13}{25}$  or 52%

9. a) 100% b) 0% c)  $\frac{6}{16}$  or 37.5%

10. a)  $\frac{9}{36}$  or 25% b)  $\frac{6}{36}$  or 16.7% c)  $\frac{21}{36}$  or 58.3%

11. a)

		Song 2				
		A	A	B	C	D
Song 1	A	A, A	A, A	A, B	A, C	A, D
	A	A, A	A, A	A, B	A, C	A, D
	B	B, A	B, A	B, B	B, C	B, D
	C	C, A	C, A	C, B	C, C	C, D
D	D, A	D, A	D, B	D, C	D, D	

b)  $\frac{4}{25}$  or 16%

### 5.5 Conduct Probability Experiments, pages 187–189

4. a) 2 boys b)  $\frac{26}{100}$  or 26% c)  $\frac{1}{4}$  or 25%

5. a)  $\frac{27}{100}$  or 27% b)  $\frac{1}{4}$  or 25%

c) Answers will vary. The experimental probability is greater than the theoretical probability.

6. a)  $\frac{7}{20}$  or 35% b)  $\frac{1}{4}$  or 25%

c) Answers will vary. The experimental probability is greater than the theoretical probability.

7. a)  $\frac{12}{20}$  or 60% b)  $\frac{1}{2}$  or 50%

c) Answers will vary. The experimental probability is greater than the theoretical probability.

8. a), b) and d) Answers will vary. c)  $\frac{1}{2}$  or 50%

9. a) 7 b)  $\frac{7}{50}$  or 14% c)  $\frac{1}{10}$  or 10% d) Answers may vary.

		Right Button	
		1	2
Left Button	S	S, 1	S, 2
	N	N, 1	N, 2
	A	A, 1	A, 2
	C	C, 1	C, 2
K	K, 1	K, 2	

10. Answers will vary.

11. a)  $\frac{125}{530}$  or 23.6% b)  $\frac{1}{4}$  or 25% c)  $\frac{130}{530}$  or 24.5%

12. Answers will vary.

13. Answers will vary.

## Chapter 5 Review, pages 190–191

- favourable, possible
- experimental
- tree diagram
- random; an event where every outcome has an equal chance of occurring
- $\frac{2}{5}$  or 2:5 or 40%
- a)  $\frac{0}{10}$  or 0:10 or 0%  
b)  $\frac{2}{10}$  or 2:10 or 20%  
c)  $\frac{3}{10}$  or 3:10 or 30%  
d)  $\frac{6}{10}$  or 6:10 or 60%

		Spinner		
		Broccoli	Beans	Carrots
Coin	Salad (S)	S, broccoli	S, beans	S, carrots
	Cooked (C)	C, broccoli	C, beans	C, carrots

		Dessert	
		Sundae (S)	Pie (P)
Dinner	Quiche	quiche, S	quiche, P
	Burger	burger, S	burger, P
	Surprise	surprise, S	surprise, P
	Special	special, S	special, P

8. a) **b) 8**

		Flip 1	Flip 2	Outcome
		H	H	H
H	T	H	(H, T)	
T	H	T	(T, H)	
T	T	T	(T, T)	

9. a) **b)  $\frac{1}{4}$  or 25%**

10. a)

		Pail						
		Nail (n)	Screw (s)	Screw (s)	Screw (s)	Screw (s)	Hook (h)	Hook (h)
Tool Box	Hammer (H)	H, n	H, s	H, s	H, s	H, s	H, h	H, h
	Screwdriver (S)	S, n	S, s	S, s	S, s	S, s	S, h	S, h
	Pliers (P)	P, n	P, s	P, s	P, s	P, s	P, h	P, h
	Tape Measure (T)	T, n	T, s	T, s	T, s	T, s	T, h	T, h

- b)  $\frac{1}{28}$  or 3.6% c) 0

11. a) Answers may vary. Roll a 4-sided die and then spin a 4-section spinner.

- b)  $\frac{4}{16}$  or 25% c)  $\frac{4}{16}$  or 25% d)  $\frac{6}{16}$  or 37.5%

Spinner 1	Spinner 2	Outcome
L	Y	(L, Y)
	O	(L, O)
	U	(L, U)
	Y	(O, Y)
O	O	(O, O)
	U	(O, U)
	Y	(V, Y)
V	O	(V, O)
	U	(V, U)
	Y	(E, Y)
E	O	(E, O)
	U	(E, U)

12. a) **b)  $\frac{1}{12}$  or 8.3%**  
c)  $\frac{11}{12}$  or 91.7%

13. a)  $\frac{7}{20}$  b)  $\frac{1}{4}$

c) Answers may vary. The probability in a) is based on the results of an experiment.

14. a)  $\frac{8}{20}$  or 40% b)  $\frac{1}{2}$  or 50%

c) The theoretical probability is greater than the experimental probability.

## Chapter 6

### 6.1 Divisibility, pages 207–209

5. 1010, 605, 900, 325. The last digit of each number is 0 or 5.

6. 124, 3048, 1432. The number formed by the last 2 digits of each number is divisible by 2 at least twice.

7. a) 330 is divisible by neither 4 nor 8.

b) The number is divisible by 2 because 2 is a factor of 4 and a factor of 8.

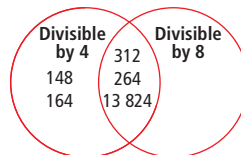

	Divisible by 6	Not Divisible by 6
Divisible by 10	35 010 9810	31 990
Not Divisible by 10	5832	243

8. a) **b) The number is divisible by 2 because 2 is a factor of 6 and a factor of 10.**

9. a) 1, 2, 3, 4, 6, 9, 12, 18, 36 b) 1, 3, 5, 15

- c) 1, 2, 4, 7, 14, 28

10. a) 1, 2, 3, 6, 9, 18

- b) 1, 2, 3, 6, 9, 18, 27, 54

- c) 1, 2, 3, 4, 6, 8, 9, 12, 18, 24, 36, 72

11. a) 1, 3 b) 1, 2, 4 c) 1, 2, 3, 6

12. a) 1, 5 b) 1, 2, 4 c) 1, 3

13. a) **b) 4**

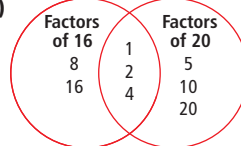

14. a)  b) 10

15. a)  $\frac{3}{4}$  b)  $\frac{1}{3}$  c)  $\frac{5}{8}$  d)  $\frac{3}{4}$  e)  $\frac{2}{5}$  f)  $\frac{3}{5}$

16. a)  $\frac{3}{4}$  b)  $\frac{1}{2}$  c)  $\frac{2}{5}$  d)  $\frac{7}{12}$  e)  $\frac{1}{2}$  f)  $\frac{4}{5}$

17. a) A, B, C, D b) A, B, E

c) Answers may vary. Choose the flowers that can be divided into both groups of 2 and groups of 3 because 2 and 3 are factors of 6.

18. Answers may vary. a) 12 345 b) 1 234 698

19. a) No b) Yes c) No

20. Yes. Answers may vary. 2 and 3 are factors of 6; 2 and 5 are factors of 10; 3 and 5 are factors of 15.

21. Answers may vary. A number is divisible by 9 if the sum of the digits is divisible by 3 twice.

22. a) 9 students b) 6 komatiks

23. No. Answers may vary. It is not possible to divide 12 peaches into 0 groups.

24. 8 teams

25. a) B, D b) B: 77 barrels; D: Answers may vary. 122 pails and 3 jugs

26. a) 3 cm b) 4 cm

27. 61 sandwiches

28. a) 1 b) 2 c) 0

## 6.2 Add Fractions With Like Denominators, pages 214–216

5. Estimates may vary.

a)  $\frac{2}{6} + \frac{2}{6} = \frac{4}{6}$  b)  $\frac{1}{3} + \frac{2}{3} = 1$  c)  $\frac{4}{6} + \frac{1}{6} = \frac{5}{6}$

6. Estimates may vary.

a)  $\frac{1}{3} + \frac{1}{3} = \frac{2}{3}$  b)  $\frac{2}{6} + \frac{1}{6} = \frac{3}{6}$  c)  $\frac{2}{4} + \frac{1}{4} = \frac{3}{4}$

7. a)  $\frac{1}{4} + \frac{1}{4} = \frac{2}{4}$  b)  $\frac{2}{5} + \frac{3}{5} = \frac{5}{5}$  c)  $\frac{2}{8} + \frac{2}{8} = \frac{4}{8}$   
 $= \frac{1}{2}$   $= 1$   $= \frac{1}{2}$

8. a)  $\frac{2}{4} + \frac{1}{4} = \frac{3}{4}$  b)  $\frac{5}{8} + \frac{1}{8} = \frac{6}{8}$  c)  $\frac{4}{10} + \frac{3}{10} = \frac{7}{10}$   
 $= \frac{3}{4}$

9. a)  $\frac{1}{3}$  b)  $\frac{1}{2}$  c)  $\frac{4}{5}$  d)  $\frac{1}{2}$  e) 1 f)  $\frac{1}{3}$

10. a)  $\frac{3}{7}$  b)  $\frac{5}{6}$  c)  $\frac{2}{3}$  d)  $\frac{2}{3}$  e) 1 f)  $\frac{3}{5}$

11. Yes.  $\frac{4}{9} + \frac{5}{9} = \frac{9}{9}$   
 $= 1$

12. a) No. His diagrams were not the same size.

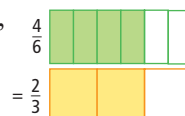
b) Answers may vary. For example, 

13. a) No b)  $\frac{4}{10} = \frac{2}{5}$

14. No. They used  $\frac{3}{4}$  of the batter.  $\frac{5}{8} + \frac{1}{8} = \frac{6}{8}$   
 $= \frac{3}{4}$

15. a)-b)

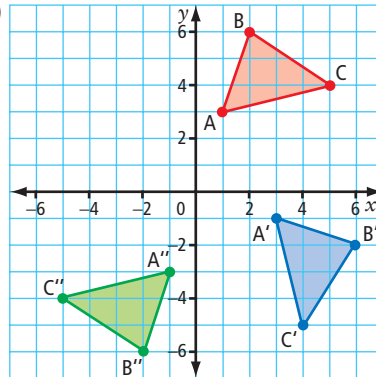

c)  $\frac{1}{4} + \frac{1}{4} = \frac{2}{4}$   
 $= \frac{1}{2}$

16.  $\frac{3}{4}$  h. Answers may vary.

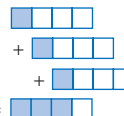
For example, 

17. a) Answers may vary.

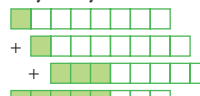
For example, 

b) Answers may vary.

For example, 

c)  $\frac{5}{8}$ . Answers may vary.  $\frac{5}{8} = \frac{15}{24}$  and  $\frac{7}{12} = \frac{14}{24}$ .  $\frac{15}{24} > \frac{14}{24}$

18. a)  $\frac{9}{8}$  b) No. She has 1 bag of beads =  $\frac{8}{8}$  bag of beads.

## 6.3 Subtract Fractions With Like Denominators, pages 220–221

4. a)  $\frac{6}{6} - \frac{2}{6} = \frac{4}{6}$  b)  $\frac{2}{3} - \frac{1}{3} = \frac{1}{3}$  c)  $\frac{4}{6} - \frac{1}{6} = \frac{3}{6}$

5. a)  $\frac{2}{3} - \frac{1}{3} = \frac{1}{3}$  b)  $\frac{3}{6} - \frac{1}{6} = \frac{2}{6}$  c)  $\frac{4}{4} - \frac{1}{4} = \frac{3}{4}$

6. a)  $\frac{5}{7} - \frac{3}{7} = \frac{2}{7}$  b)  $\frac{8}{10} - \frac{4}{10} = \frac{4}{10}$  c)  $\frac{7}{12} - \frac{3}{12} = \frac{4}{12}$   
 $= \frac{2}{5}$   $= \frac{1}{3}$

7. a)  $\frac{4}{5} - \frac{3}{5} = \frac{1}{5}$  b)  $\frac{5}{8} - \frac{1}{8} = \frac{4}{8}$  c)  $\frac{11}{12} - \frac{3}{12} = \frac{8}{12}$   
 $= \frac{1}{2}$   $= \frac{2}{3}$

8. a)  $\frac{1}{7}$  b)  $\frac{1}{3}$  c)  $\frac{1}{3}$  d)  $\frac{2}{9}$  e)  $\frac{2}{5}$  f)  $\frac{3}{5}$

9. a)  $\frac{2}{3}$  b)  $\frac{7}{9}$  c) 0 d)  $\frac{1}{2}$  e)  $\frac{7}{10}$  f)  $\frac{1}{2}$

10.  $\frac{1}{6}$  of the pizza is left.

11. Yes, he will be halfway through because  $\frac{3}{4} - \frac{1}{4} = \frac{1}{2}$ .

12. a)  $\frac{4}{9}$ . No. b) She needs  $\frac{1}{9}$  of a bag more.

13.  $\frac{5}{8}$  and  $\frac{3}{8}$

14. a) No b) He needs  $\frac{1}{5}$  of a box more.

### Chapter 6 Review, pages 222–223

- lowest terms
- divisible
- common factor

	2	3	4	5	6	8	9	10
630	✓	✓	✗	✓	✓	✗	✓	✓
5184	✓	✓	✓	✗	✓	✓	✓	✗
2035	✗	✗	✗	✓	✗	✗	✗	✗
810	✓	✓	✗	✓	✓	✗	✓	✓

5. a) 210 is divisible by 2 because the last digit is an even number, and 210 is divisible by 5 and 10 because the last digit is 0.

b) 1232 is divisible by 4 because 1232 is divisible by 2 at least twice, and 1232 is divisible by 8 because 1232 is divisible by 2 at least 3 times.

c) 333 is divisible by 3 and 9 because the sum of the digits is divisible by 3 and 9. 333 is not divisible by 6 because it must be divisible by both 2 and 3 and it is not divisible by 2.

6. Answers may vary.  $3 \times 5 = 15$      $15 \div 3 = 5$   
 $2 \times 5 = 10$      $10 \div 2 = 5$   
 $1 \times 5 = 5$      $5 \div 1 = 5$   
 $0 \times ? = 5$      $5 \div 0 = ?$

The pattern shows that there is no number that 0 can be multiplied by that will equal 5. That means that when 5 is divided by 0, there is no possible answer.

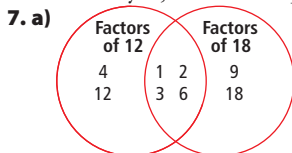

The greatest common factor of 12 and 18 is 6.

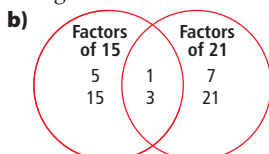

The greatest common factor of 15 and 21 is 3.

8. a)  $\frac{1}{2}$  b)  $\frac{3}{5}$  c)  $\frac{2}{3}$  d)  $\frac{5}{8}$  e)  $\frac{3}{4}$  f)  $\frac{5}{12}$

9. 6 groups

10. a)  $\frac{1}{2} + \frac{1}{2} = \frac{2}{2} = 1$  b)  $\frac{2}{6} + \frac{2}{6} = \frac{4}{6} = \frac{2}{3}$  c)  $\frac{1}{3} + \frac{1}{3} = \frac{2}{3}$

11. a)  $\frac{1}{10} + \frac{4}{10} = \frac{5}{10}$  b)  $\frac{2}{5} + \frac{1}{5} = \frac{3}{5}$  c)  $\frac{4}{10} + \frac{2}{10} = \frac{6}{10} = \frac{3}{5}$

12. a) 1 b)  $\frac{1}{2}$  c)  $\frac{1}{2}$  d)  $\frac{4}{5}$  e)  $\frac{1}{7}$  f)  $\frac{6}{7}$

13. Yes,  $\frac{3}{8} + \frac{5}{8} = \frac{8}{8} = 1$

14. a)  $\frac{4}{6} - \frac{1}{6} = \frac{3}{6} = \frac{1}{2}$  b)  $\frac{3}{3} - \frac{1}{3} = \frac{2}{3}$

15. a)  $\frac{7}{8} - \frac{5}{8} = \frac{2}{8} = \frac{1}{4}$  b)  $\frac{3}{5} - \frac{1}{5} = \frac{2}{5}$

16. a)  $\frac{1}{3}$  b)  $\frac{3}{4}$  c) 0 d)  $\frac{3}{5}$  e)  $\frac{1}{2}$  f)  $\frac{3}{5}$

17. a) No. He needs  $\frac{1}{5}$  of a jar more.

b)  $\frac{3}{5}$  of a jar

## Chapter 7

### 7.1 Common Denominators, pages 234–236

4. a) common denominator: 12;  $\frac{1}{4} = \frac{3}{12}$ ,  $\frac{2}{3} = \frac{8}{12}$

b) common denominator: 8;  $\frac{1}{2} = \frac{4}{8}$ ,  $\frac{3}{4} = \frac{6}{8}$

5. a) common denominator: 15;  $\frac{1}{3} = \frac{5}{15}$ ,  $\frac{3}{5} = \frac{9}{15}$

b) common denominator: 24;  $\frac{5}{6} = \frac{20}{24}$ ,  $\frac{1}{4} = \frac{6}{24}$

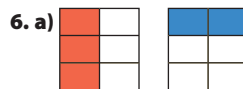

common denominator: 6;  $\frac{1}{2} = \frac{3}{6}$ ,  $\frac{1}{3} = \frac{2}{6}$



common denominator: 15;  $\frac{2}{3} = \frac{10}{15}$ ,  $\frac{1}{5} = \frac{3}{15}$

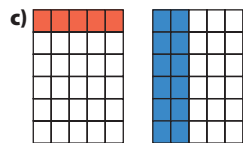

common denominator: 30;  $\frac{1}{6} = \frac{5}{30}$ ,  $\frac{2}{5} = \frac{12}{30}$

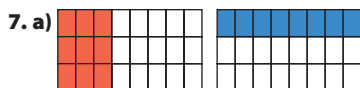

common denominator: 24;  $\frac{3}{8} = \frac{9}{24}$ ,  $\frac{1}{3} = \frac{8}{24}$

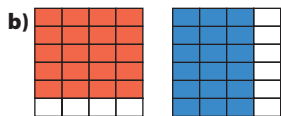

common denominator: 24;  $\frac{5}{6} = \frac{20}{24}$ ,  $\frac{3}{4} = \frac{18}{24}$

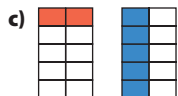

common denominator: 10;  $\frac{1}{5} = \frac{2}{10}$ ,  $\frac{1}{2} = \frac{5}{10}$

8. a)  $10; \frac{1}{2} = \frac{5}{10}, \frac{2}{5} = \frac{4}{10}$

b)  $12; \frac{1}{3} = \frac{4}{12}, \frac{1}{4} = \frac{3}{12}$

c)  $24; \frac{5}{8} = \frac{15}{24}, \frac{1}{6} = \frac{4}{24}, \frac{5}{12} = \frac{10}{24}$

9. a)  $8; \frac{3}{8}, \frac{1}{4} = \frac{2}{8}$

b)  $12; \frac{1}{6} = \frac{2}{12}, \frac{1}{4} = \frac{3}{12}$

c)  $30; \frac{1}{5} = \frac{6}{30}, \frac{2}{3} = \frac{20}{30}, \frac{7}{10} = \frac{21}{30}$

10. a)  $16; \frac{13}{16}$  is larger.

b)  $49; \frac{36}{49}$  is larger.

c)  $30; \frac{11}{30}$  is larger.

d) 27; the fractions are equal.

11.

Multiples of 4		Multiples of 6	
4	8	12	6
16	20	24	18
28	32	36	30
40	44	48	42

12. a)  $\frac{1}{4} = \frac{2}{8} = \frac{3}{12} = \frac{4}{16} = \frac{5}{20} = \frac{6}{24} = \frac{7}{28}$

b)  $\frac{1}{5} = \frac{2}{10} = \frac{3}{15} = \frac{4}{20} = \frac{5}{25} = \frac{7}{35} = \frac{11}{55}$

c)  $\frac{24}{56} = \frac{12}{28} = \frac{6}{14} = \frac{3}{7} = \frac{48}{112} = \frac{9}{21}$

d)  $\frac{30}{48} = \frac{15}{24} = \frac{10}{16} = \frac{5}{8} = \frac{60}{96} = \frac{20}{32}$

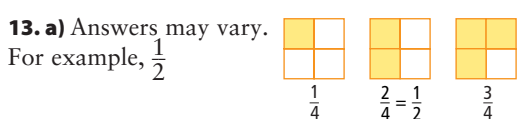

b) Answers may vary. For example,  $\frac{3}{6}, \frac{4}{6}$

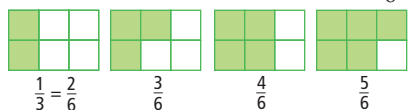

c) Answers may vary. For example,  $\frac{5}{10}, \frac{6}{10}, \frac{7}{10}$

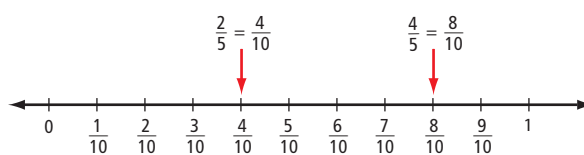

14.  $12; \frac{1}{3} = \frac{4}{12}, \frac{1}{4} = \frac{3}{12}, \frac{5}{6} = \frac{10}{12}, \frac{2}{3} = \frac{8}{12}, \frac{3}{4} = \frac{9}{12}, \frac{1}{2} = \frac{6}{12}, \frac{1}{4}, \frac{1}{3}, \frac{2}{3}, \frac{3}{4}, \frac{5}{6}$

15. a) Answers may vary.  $\frac{1}{2}$  of the rectangle is 3 of the 6 squares.  $\frac{1}{3}$  of the rectangle is 2 of the 6 squares. The common denominator is 6.

b) common denominator: 28



16. a) 36 b) The grass takes up more space.

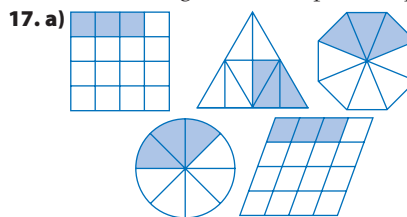

b) Answers may vary.

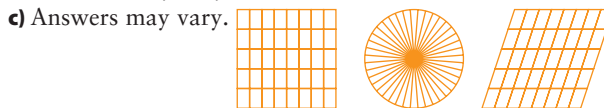

d) Answers may vary.

18.  $\frac{1}{2}, \frac{1}{3}, \frac{2}{3}, \frac{1}{4}, \frac{3}{4}, \frac{1}{5}, \frac{2}{5}, \frac{3}{5}, \frac{4}{5}, \frac{1}{6}, \frac{5}{6}, \frac{1}{7}, \frac{2}{7}, \frac{3}{7}, \frac{4}{7}, \frac{5}{7}, \frac{6}{7}$   
 $\frac{1}{8}, \frac{3}{8}, \frac{5}{8}, \frac{7}{8}, \frac{1}{9}, \frac{2}{9}, \frac{4}{9}, \frac{5}{9}, \frac{7}{9}, \frac{8}{9}$

19. A

20. D

21. a) kindergarten

b) grade 5

c) grade 4 and grade 6

d) 360

## 7.2 Add and Subtract Fractions With Unlike Denominators, pages 242–244

4. Estimates may vary.

a)  $\frac{1}{4} + \frac{1}{2} = \frac{1}{4} + \frac{2}{4} = \frac{3}{4}$       b)  $\frac{2}{5} + \frac{3}{10} = \frac{4}{10} + \frac{3}{10} = \frac{7}{10}$

c)  $\frac{1}{6} + \frac{3}{4} = \frac{2}{12} + \frac{9}{12} = \frac{11}{12}$

5. a)  $\frac{2}{5} + \frac{6}{10} = \frac{4}{10} + \frac{6}{10}$   
 $= \frac{10}{10}$   
 $= 1$

b)  $\frac{3}{8} + \frac{1}{4} = \frac{3}{8} + \frac{2}{8}$  c)  $\frac{1}{7} + \frac{1}{2} = \frac{2}{14} + \frac{7}{14}$   
 $= \frac{5}{8}$   $= \frac{9}{14}$

6. a)  $\frac{1}{2}$  b)  $\frac{7}{8}$  c)  $\frac{3}{4}$  d)  $\frac{17}{20}$  e)  $\frac{7}{10}$  f)  $\frac{13}{24}$

7. a)  $\frac{7}{8}$  b)  $\frac{11}{12}$  c) 1 d)  $\frac{5}{9}$  e)  $\frac{9}{10}$  f)  $\frac{11}{12}$

8. a)  $\frac{1}{2} + \frac{1}{3} = \frac{3}{6} + \frac{2}{6}$  b)  $\frac{1}{6} + \frac{1}{3} = \frac{1}{6} + \frac{2}{6}$   
 $= \frac{5}{6}$   $= \frac{3}{6}$

9. Estimates may vary.

a)  $\frac{3}{4} - \frac{3}{8} = \frac{6}{8} - \frac{3}{8}$  b)  $\frac{7}{10} - \frac{1}{5} = \frac{7}{10} - \frac{2}{10}$   
 $= \frac{3}{8}$   $= \frac{5}{10}$

c)  $\frac{2}{3} - \frac{3}{5} = \frac{10}{15} - \frac{9}{15}$   
 $= \frac{1}{15}$

10. a)  $\frac{5}{6} - \frac{2}{3} = \frac{5}{6} - \frac{4}{6}$  b)  $\frac{3}{5} - \frac{1}{2} = \frac{6}{10} - \frac{5}{10}$   
 $= \frac{1}{6}$   $= \frac{1}{10}$

c)  $\frac{9}{12} - \frac{3}{4} = \frac{9}{12} - \frac{9}{12}$   
 $= 0$

11. a)  $\frac{3}{10}$  b)  $\frac{1}{3}$  c)  $\frac{2}{5}$  d)  $\frac{3}{8}$  e)  $\frac{4}{15}$  f)  $\frac{5}{24}$

12. a)  $\frac{5}{8}$  b)  $\frac{1}{12}$  c)  $\frac{1}{6}$  d)  $\frac{1}{18}$  e)  $\frac{3}{20}$  f)  $\frac{1}{10}$

13. a)  $\frac{1}{2} - \frac{1}{6} = \frac{3}{6} - \frac{1}{6}$  b)  $\frac{2}{3} - \frac{1}{6} = \frac{4}{6} - \frac{1}{6}$   
 $= \frac{2}{6}$   $= \frac{3}{6}$

14. a)  $\frac{7}{12}$  of a tray b)  $\frac{3}{12}$  or  $\frac{1}{4}$  of a tray

15.  $\frac{1}{8}$  of a length

16. a) Answers may vary. For example, the friend added the denominators of the fractions.

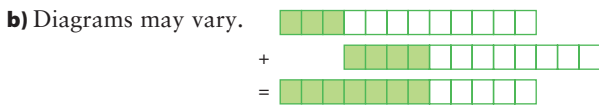

17.  $\frac{3}{6}$  or  $\frac{1}{2}$  of the plane was left.

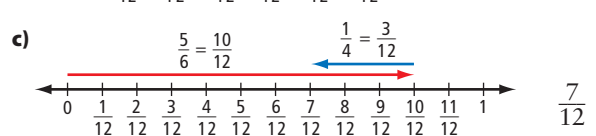
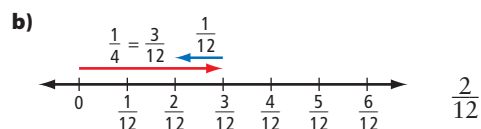
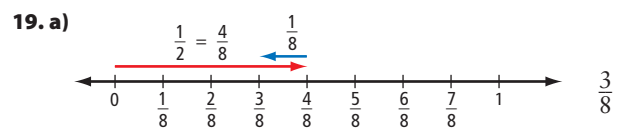
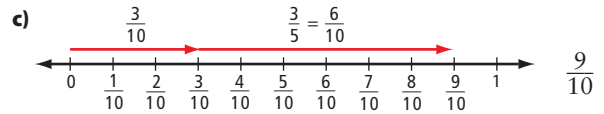
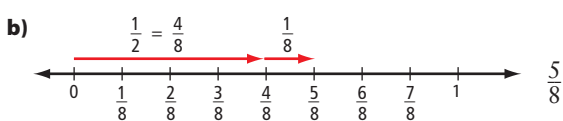
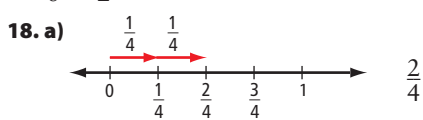

20. No.  $\frac{1}{2} + \frac{1}{4} + \frac{1}{8} + \frac{1}{16} + \frac{1}{32} + \frac{1}{64}$   
 $= \frac{32}{64} + \frac{16}{64} + \frac{8}{64} + \frac{4}{64} + \frac{2}{64} + \frac{1}{64}$   
 $= \frac{63}{64}$

21. a)  $\frac{3}{5}$  full b) 5 h

22.

$\frac{1}{6}$	$\frac{5}{12}$	$\frac{5}{12}$
$\frac{7}{12}$	$\frac{1}{3}$	$\frac{1}{12}$
$\frac{1}{4}$	$\frac{1}{4}$	$\frac{1}{2}$

23. a)  $B = \frac{1}{4}$ ,  $C = \frac{1}{8}$ ,  $D = \frac{1}{16}$ ,  $E = \frac{1}{8}$ ,  $F = \frac{1}{16}$ ,  $G = \frac{1}{8}$

b)  $\frac{2}{4} = \frac{1}{2}$  c)  $\frac{15}{16}$  d) D and F e) Answers will vary.

### 7.3 Add Mixed Numbers, pages 249–251

4. a)  $1\frac{1}{3} + \frac{1}{3}$  b)  $1\frac{2}{6} + 1\frac{3}{6}$  c)  $2\frac{5}{8} + 2\frac{4}{8}$

5. a)  $1\frac{2}{4} + 1\frac{1}{4}$  b)  $1\frac{2}{5} + 2\frac{3}{5}$  c)  $1\frac{2}{6} + \frac{4}{6}$

6. a)  $2\frac{2}{3}$  b)  $8\frac{3}{4}$  c) 2 d)  $5\frac{4}{5}$  e)  $5\frac{1}{5}$  f)  $6\frac{2}{3}$

7. a)  $3\frac{3}{5}$  b)  $4\frac{3}{4}$  c)  $5\frac{2}{3}$  d) 5 e)  $3\frac{2}{5}$  f)  $11\frac{1}{2}$

8. a)  $1\frac{2}{3} + 1\frac{1}{6}$  b)  $2\frac{1}{4} + 1\frac{1}{2}$  c)  $2\frac{7}{10} + 1\frac{2}{5}$

9. a)  $1\frac{1}{3} + 1\frac{2}{6}$  b)  $\frac{3}{4} + 1\frac{1}{6}$  c)  $3\frac{5}{12} + 2\frac{3}{4}$

10. a)  $3\frac{7}{10}$  b)  $5\frac{2}{3}$  c)  $3\frac{7}{12}$  d)  $5\frac{4}{5}$  e)  $7\frac{2}{3}$  f)  $10\frac{8}{21}$

11. a)  $6\frac{1}{2}$  b)  $6\frac{9}{10}$  c)  $6\frac{9}{20}$  d)  $9\frac{11}{30}$  e)  $2\frac{7}{12}$  f)  $7\frac{2}{5}$

12. 4 h

13.  $2\frac{5}{8}$  pages



14.  $4\frac{5}{6}$  dozen eggs. Estimates may vary.

For example,  $2 + 3 = 5$  dozen eggs.

15. He cut  $3\frac{11}{12}$  trays of spinach pie. Diagrams may vary.

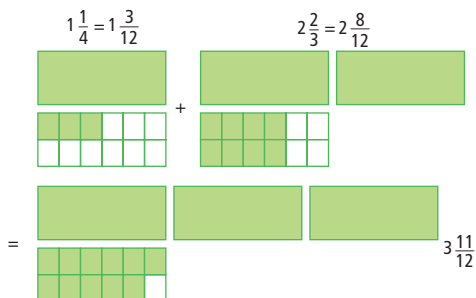

16.  $2\frac{1}{12}$  h. Estimates may vary. For example,  $1 + 1 = 2$  h.

17. a) Jonas b)  $4\frac{4}{15}$  boxes c)  $5\frac{2}{15}$  boxes

18. a) Answers may vary. 12 h. Yes, she met her goal.

b) 11 h

c) Answers may vary. Yes, the estimate of 12 h is a little more than 11 h.

19. a) Diagrams may vary.

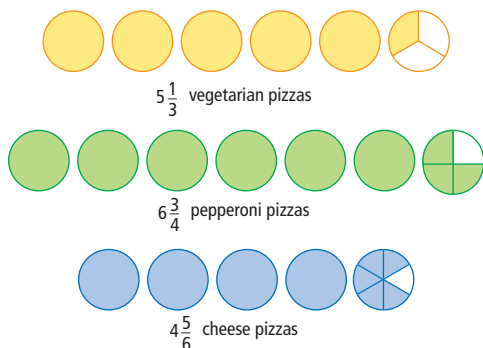

b) Estimates may vary. 17 pizzas. There were  $16\frac{11}{12}$  pizzas sold.

20. a)  $4\frac{1}{30}$  h b)  $6\frac{17}{60}$  p.m.

#### 7.4 Subtract Mixed Numbers, pages 257–259

3. a)  $3\frac{2}{3} - 2\frac{1}{3}$  b)  $2\frac{3}{6} - 2\frac{1}{6}$  c)  $2\frac{3}{10} - 1\frac{7}{10}$

4. a)  $2\frac{3}{4} - 1\frac{1}{4}$  b)  $2\frac{2}{5} - 2\frac{1}{5}$  c)  $3\frac{1}{8} - 2\frac{2}{8}$

5. a)  $\frac{1}{5}$  b)  $1\frac{1}{4}$  c) 2 d)  $1\frac{1}{2}$  e)  $1\frac{1}{3}$  f)  $2\frac{6}{7}$

6. a)  $1\frac{4}{9}$  b) 0 c)  $3\frac{3}{5}$  d)  $1\frac{2}{5}$  e)  $\frac{5}{12}$  f)  $\frac{3}{4}$

7. a)  $3\frac{5}{8} - 2\frac{2}{4}$  b)  $2\frac{3}{10} - 1\frac{3}{5}$  c)  $4\frac{7}{12} - 2\frac{3}{4}$

8. a)  $2\frac{3}{4} - 1\frac{1}{2}$  b)  $1\frac{6}{8} - \frac{2}{4}$  c)  $3\frac{3}{7} - 2\frac{1}{2}$

9. a)  $3\frac{3}{10}$  b)  $4\frac{3}{10}$  c)  $4\frac{3}{10}$  d)  $2\frac{8}{9}$  e)  $\frac{2}{15}$  f)  $1\frac{5}{14}$

10. a)  $2\frac{1}{10}$  b)  $\frac{1}{12}$  c)  $2\frac{7}{18}$  d)  $1\frac{5}{6}$  e)  $2\frac{5}{12}$  f)  $\frac{19}{20}$

11.  $\frac{2}{3}$  h of practice

12.  $5\frac{1}{4}$  bottles

13. a)  $2\frac{1}{4}$  h longer

b) Answers may vary.  $4 - 2 = 2$

14. Diagrams may vary.

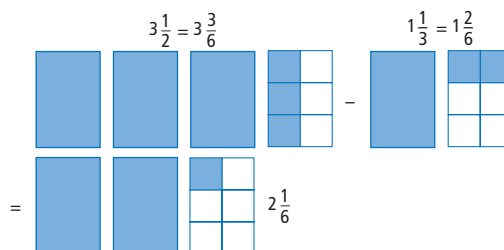

Julia needs  $2\frac{1}{6}$  more packages of Saskatoon berries.

15. Mark has collected  $\frac{7}{12}$  more of a set.

16. a) Alex needs to complete  $10\frac{3}{4}$  h more.

b) Methods for checking may vary.

$13\frac{1}{2} - 2\frac{3}{4} \approx 14 - 3 = 11$  h

17. Mei ran  $\frac{1}{12}$  lap farther.

18. a)  $2\frac{1}{4}$  b)  $1\frac{1}{2}$  c)  $3\frac{7}{12}$

19. Diagrams may vary.

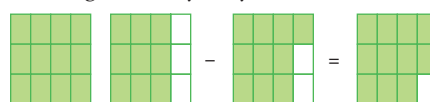

$\frac{11}{12}$  of a tray of dinner rolls is left.

20. a)  $3\frac{1}{4}$  h b)  $15\frac{3}{4}$  h c)  $8\frac{1}{4}$  h

21. a)  $\frac{1}{2}$  h b) Answers may vary.

22. a)  $\frac{17}{20}$  or 0.85 pieces of construction paper

b)  $7\frac{7}{20}$  or 7.35 pieces of construction paper

23. a)  $\frac{5}{6}$  of a package b) 10 golf balls

#### Chapter 7 Review, pages 260–261

1. multiple

2. improper fraction

3. mixed number

4. common denominator

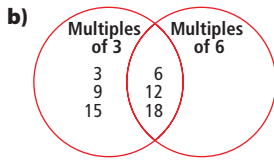
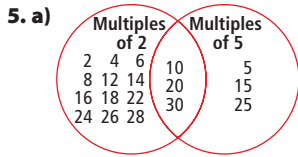

**6.** Answers may vary. **a)** 8 **b)** 15 **c)** 12 **d)** 20

**7.** common denominator: 12; equivalent fractions:  $\frac{6}{12}$ ,

$\frac{2}{12}$ ,  $\frac{8}{12}$ ,  $\frac{9}{12}$ ,  $\frac{7}{12}$ ; from greatest to least:  $\frac{3}{4}$ ,  $\frac{2}{3}$ ,  $\frac{7}{12}$ ,  $\frac{1}{2}$ ,  $\frac{1}{6}$

**8. a)**  $\frac{2}{3} + \frac{1}{4} = \frac{8}{12} + \frac{3}{12} = \frac{11}{12}$  **b)**  $\frac{3}{8} + \frac{1}{2} = \frac{3}{8} + \frac{4}{8} = \frac{7}{8}$

**9. a)**  $\frac{7}{9} - \frac{4}{6} = \frac{14}{18} - \frac{12}{18} = \frac{2}{18}$  **b)**  $1 - \frac{1}{2} = \frac{1}{2}$

**10. a)**  $\frac{1}{2}$  **b)**  $\frac{1}{2}$  **c)**  $1\frac{7}{20}$  **d)**  $\frac{7}{12}$  **e)**  $1\frac{7}{12}$  **f)**  $\frac{23}{30}$

**11. a)**  $\frac{1}{4}$  **b)**  $\frac{1}{3}$  **c)**  $\frac{1}{3}$  **d)**  $\frac{4}{15}$  **e)** 0 **f)**  $\frac{7}{24}$

**12.** Diagrams may vary.

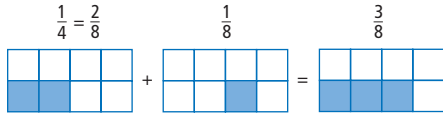

The bin is  $\frac{7}{8}$  full.

**13.** June-el ran  $\frac{1}{6}$  h more yesterday.

Methods for checking may vary.

**14. a)**  $\frac{5}{12}$  of the bag **b)**  $\frac{1}{4}$  of the bag

**15. a)**  $2\frac{3}{10} + 2\frac{6}{10}$  **b)**  $3\frac{3}{4} + 2\frac{1}{2}$

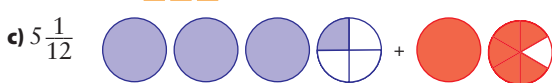
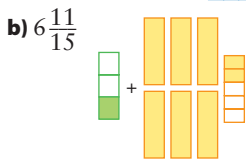
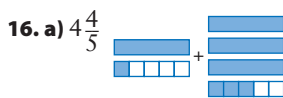

**17. a)**  $4\frac{1}{2}$  **b)**  $4\frac{9}{10}$  **c)**  $4\frac{1}{3}$  **d)** 10 **e)**  $6\frac{3}{4}$  **f)**  $10\frac{17}{24}$

**18.**  $8\frac{1}{6}$  rooms. Methods of checking may vary.

For example,  $2\frac{5}{12} + 5\frac{3}{4} \approx 2 + 6 = 8$

**19. a)**  $2\frac{3}{5} - 1\frac{3}{5}$  **b)**  $2\frac{1}{4} - \frac{2}{3}$

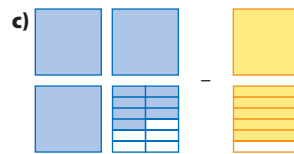
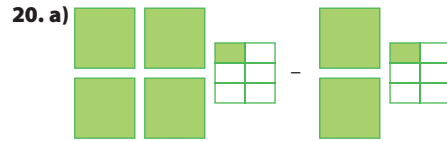

**21. a)**  $\frac{1}{2}$  **b)**  $1\frac{1}{5}$  **c)**  $2\frac{5}{12}$  **d)**  $1\frac{1}{2}$  **e)**  $1\frac{1}{2}$  **f)**  $\frac{19}{21}$

**22. a)**  $\frac{7}{12}$  of a bag **b)**  $3\frac{1}{2}$  bags

## Chapter 8

### 8.1 Construct Circles, pages 271–272

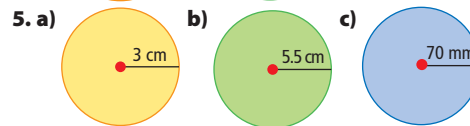
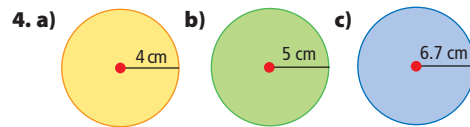

**6. a)** 10 cm **b)** 16 cm **c)** 190 mm

**7. a)** 2 cm **b)** 3.5 cm **c)** 43 mm

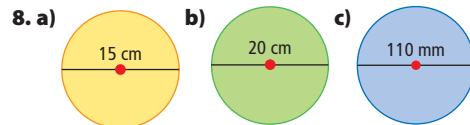

**9. a)–b)** Length AB is the radius of each circle.

**10.** Circle A is bigger. Circle A has a radius of 25 cm and a diameter of 50 cm. Circle B has a radius of 22.5 cm and a diameter of 45 cm.

**11.** Always true.

**12.** Designs may vary.

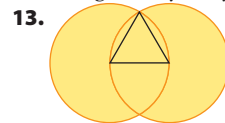

**a)** triangle

**b)** Answers will vary. The sides of the triangle are all radii of one or both of the 2 intersecting congruent circles.

**14.** Answers may vary.

**15.** Answers may vary.

## 8.2 Circumference of a Circle, pages 278–279

3. a) 6 km; 6.6 km b) 3 m; 2.8 m  
 4. a) 90 mm; 87.9 mm b) 6 cm; 6.3 cm  
 5. 9 km  
 6. 41 km  
 7. a) 6 km; 5.0 km b) 18 m; 17.0 m  
 8. a) 6 m; 6.3 m b) 120 mm; 125.6 mm  
 9. 30.1 m  
 10. 7.5 m  
 11. 56.5 m  
 12. 10 frames  
 13. a) 144.1 m b) 24 cars  
 14. Always true.  
 15. Answers may vary. Yes. The diameter of the hoop is 0.51 m. The basketballs have a combined diameter of 0.48 m.  $0.51 - 0.48 = 0.03$ . Therefore, 2 basketballs could fit through the hoop at the same time.  
 16. Answers may vary. For example, if you use  $C = \pi \times d$ , the diameter would equal the circumference divided by pi.  
 17. a) 70.4 mm b) 27.3 cm  
 18. 5.7 m  
 19. approximately 71 more turns

## 8.3 Area of a Circle, pages 285–286

4. a) 2700 mm<sup>2</sup>; 3215.4 mm<sup>2</sup>  
 b) 3 km<sup>2</sup>; 1.5 km<sup>2</sup>  
 5. a) 675 cm<sup>2</sup>; 706.5 cm<sup>2</sup>  
 b) 27 m<sup>2</sup>; 36.3 m<sup>2</sup>  
 6. 113.0 m<sup>2</sup>  
 7. a) 1384.7 cm<sup>2</sup> b) 0.1 m<sup>2</sup>  
 8. a) 551.3 cm<sup>2</sup> b) 0.07 km<sup>2</sup>  
 9. a) 171.9 m<sup>2</sup> b) 314 mm<sup>2</sup>  
 10. 510.4 m<sup>2</sup>  
 11. 9499 cm<sup>2</sup>  
 12. \$1059.75  
 13. 3039.5 cm<sup>2</sup>  
 14. Never true. For a circle with radius 5 cm, the area is 78.5 cm<sup>2</sup>. If the radius is doubled to 10 cm, the area of the new circle would be 314 cm<sup>2</sup>. This is 4 times the area of the other circle.  
 15. 414.48 mm<sup>2</sup>  
 16. a) white button: 706.5 cm<sup>2</sup>; red: 10 977.4 cm<sup>2</sup>; white: 35 051.9 cm<sup>2</sup>; blue: 58 419.7 cm<sup>2</sup>  
 b) 105 155.5 cm<sup>2</sup>  
 17. Yes, if  $r^2 = 2r$ . This will occur when the radius is 2.  
 18. a)–c) Answers may vary depending on the size of the circles drawn in part a).  
 d) Answers may vary. The area for the parallelogram is less than the area of the circle. As the circle is divided into even more wedges, the areas will become closer in value.  
 19. 12.6 cm<sup>2</sup>  
 20. 154 m<sup>2</sup>

## 8.4 Interpret Circle Graphs, pages 290–291

3. a) grade 7 b) 120 students c) 30 more students  
 4. a) 800 books b) 2600 books c) 15%  
 5. a) walk b) 26 c) 468  
 6. a) Individual skills  
 b) Individual Skills, Team Skills, Warm Up, Cool Down; Individual Skills, Scrimmage, Warm Up  
 c) Warm Up: 6 min; Individual Skills: 24 min; Team Skills: 12 min; Scrimmage: 15 min; Cool Down: 3 min

Time	Activity
5:00 p.m.	Warm Up
5:06 p.m.	Individual Skills
5:30 p.m.	Team Skills
5:42 p.m.	Scrimmage
5:57 p.m.	Cool Down
6:00 p.m.	Finish

7. a) Compact b) 8  
 8. a) Pop b) Ms. Torregrosa's class c) Jazz d) Pop, Rock  
 9. a)–f) Answers may vary.

## 8.5 Create Circle Graphs, pages 296–297

4. a)

Type	Number of Cards	Percent of Total	Decimal Value Equivalent	Central Angle
Forward	20	50%	0.50	180°
Defense	16	40%	0.40	144°
Goalie	4	10%	0.10	36°
Totals	40	100%	1.00	360°

b) Type of Hockey Card

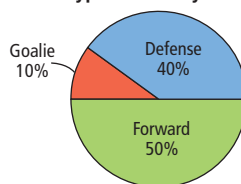

5. a)

Favourite Ice Cream	Number of Students	Percent of Total	Decimal Value Equivalent	Central Angle
Chocolate	24	40%	0.40	144°
Strawberry	15	25%	0.25	90°
Vanilla	12	20%	0.20	72°
Other	9	15%	0.15	54°
Totals	60	100%	1.00	360°

b) Favourite Flavour of Ice Cream (Grade 7s)

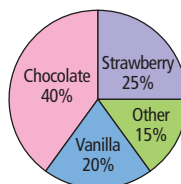

**6. Favourite School Subject**

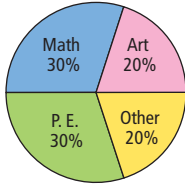

**7. Homework Hours**

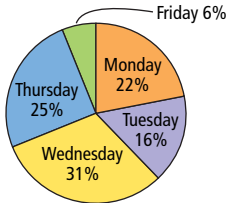

**8. Theatre Admissions**

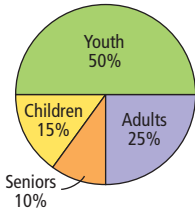

**9. Lunch Specials**

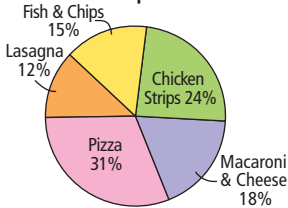

**10. a) Territory Population**

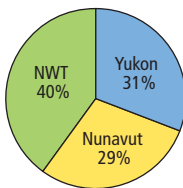

**b)** Answers may vary depending on population figures found on Internet.

**c)** Answers may vary.

**11. a)–e)** Answers may vary.

**12. a)–c)** Answers may vary.

**13. a)–d)** Answers may vary.

**Chapter 8 Review, pages 298–299**

1. B
2. F
3. A
4. C
5. E
6. D
7. H

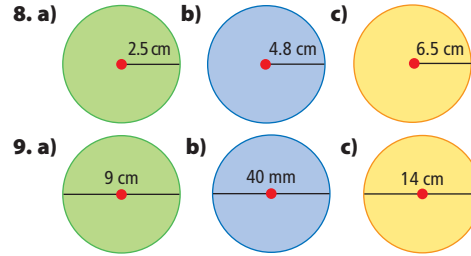

**10.** No, point B does not lie within the circle.

**11. a)** 33.9 cm **b)** 38.3 cm

**12. a)** 18.8 m **b)** 5.7 km **c)** 4.4 m **d)** 659.4 km

**13.** 3.8 m

**14. a)** 20.6 m **b)** \$149.35

**15. a)** 1218.6 cm<sup>2</sup> **b)** 221.6 cm<sup>2</sup>

**16. a)** 52.8 m<sup>2</sup> **b)** 5.3 km<sup>2</sup> **c)** 193.5 m<sup>2</sup> **d)** 514.5 mm<sup>2</sup>

**17.** 50.2 m<sup>2</sup>

**18.** 69.1 cm<sup>2</sup>

**19.** 625

**20. a)** 12 **b)** 15% **c)** soccer and baseball

**21. Radio Station Air Time Programming**

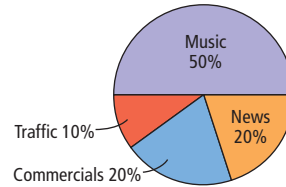

**22. a) First Nations Population**

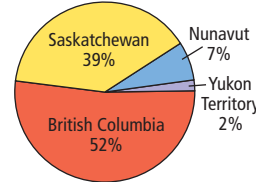

**b)** Answers may vary. The southern provinces have warmer weather and easier access to more resources.

**Chapters 5–8 Review, pages 304–306**

**1. a)**  $\frac{4}{8}$  or 4:8 or 50%

**b)**  $\frac{2}{8}$  or 2:8 or 25%

**c)**  $\frac{0}{8}$  or 0:8 or 0%

**d)**  $\frac{8}{8}$  or 8:8 or 100%

		Spinner			
		1	2	3	4
Coin Toss	Heads (H)	H, 1	H, 2	H, 3	H, 4
	Tails (T)	T, 1	T, 2	T, 3	T, 4

		Second Letter				
		a	e	i	o	u
First Letter	a	a, a	a, e	a, i	a, o	a, u
	e	e, a	e, e	e, i	e, o	e, u
	i	i, a	i, e	i, i	i, o	i, u
	o	o, a	o, e	o, i	o, o	o, u
	u	u, a	u, e	u, i	u, o	u, u

b)  $\frac{1}{25}$  c)  $\frac{2}{25}$  d)  $\frac{9}{25}$

4. a)  $\frac{4}{30}$  or 13.3% b)  $\frac{1}{6}$  or 16.7%

c) Answers may vary. The experimental probability is less than the theoretical probability.

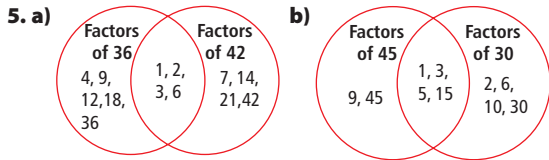

6. a)  $\frac{3}{5}$  b)  $\frac{14}{14} = 1$  c)  $\frac{8}{8} = 1$  d)  $\frac{2}{3}$

7. a)  $\frac{2}{7}$  b) 0 c)  $\frac{1}{2}$  d)  $\frac{3}{5}$

8. No, she needs another  $\frac{1}{8}$  of a bag.

9. a)  $\frac{1}{8}$  b)  $\frac{1}{2}$  c)  $4\frac{1}{10}$  d)  $2\frac{3}{4}$

10. a)  $\frac{7}{9}$  b)  $\frac{9}{20}$  c)  $3\frac{2}{3}$  d)  $3\frac{1}{2}$  e)  $1\frac{5}{12}$  f)  $8\frac{3}{10}$

11. a)  $1\frac{7}{12}$  trays b)  $\frac{3}{8}$  of a tray c)  $1\frac{23}{24}$  trays

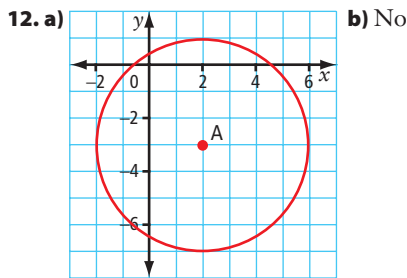

13. a) circumference: 27.0 cm; area: 58.1 cm<sup>2</sup>

b) circumference: 32.0 cm; area: 81.7 cm<sup>2</sup>

14. 188.4 cm

15. a)-c)

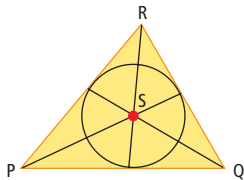

16. It is 4 times larger. For example, if  $r = 5$  cm,  $A = 78.5$  cm<sup>2</sup>. If  $r = 10$  cm,  $A = 314$  cm<sup>2</sup>.  $314 \div 78.5 = 4$

17. a) Scrimmage

b) Scrimmage, Technique, Warm Up; Scrimmage, Drills, Warm Up

c) Warm Up: 6 min; Drills: 15 min; Technique: 15 min; Scrimmage: 21 min; Cool Down: 3 min

Time	Activity
4:00 p.m.	Warm Up
4:06 p.m.	Drills
4:21 p.m.	Technique
4:36 p.m.	Scrimmage
4:57 p.m.	Cool Down
5:00 p.m.	Finish

18. Favourite Weekend Activities

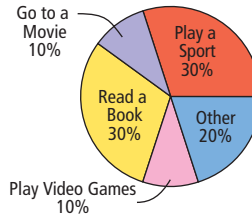

## Chapter 9

### 9.1 Explore Integer Addition, pages 313–315

5. a)  $(+5) + (-5) = 0$

b)  $(-6) + (+4) = -2$

c)  $(-4) + (+8) = +4$

6. a)  $(+6) + (-9) = -3$

b)  $(-4) + (+4) = 0$

c)  $(+7) + (-3) = +4$

7. a) +7 b) -6 c) +3 d) 0

8. a) -5 b) +8 c) -3 d) +5

9. a) \$6 left b) 2 cm below c) won by 3 goals

d) 12 m under the water

10. -\$15

11. -4°C

12. a)  $(+6) + (+2) = +8$  b)  $(-5) + (+8) = +3$

c)  $(+4) + (-4) = 0$  d)  $(+6) + (-2) = +4$

13. a)

$(+2) + (+3) = +5$	$(+3) + (+2) = +5$
$(-1) + (-4) = -5$	$(-4) + (-1) = -5$
$(+2) + (-2) = 0$	$(-2) + (+2) = 0$
$(+4) + (-7) = -3$	$(-7) + (+4) = -3$

b) The order in which you add 2 integers does not change the sum.

14. a) 5 red chips = +5,

7 red chips + 2 blue chips =  $(+7) + (-2) = +5$ ,

10 red chips + 5 blue chips =  $(+10) + (-5) = +5$

b) Answers will vary. For example,

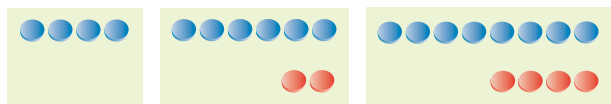

15. 0

16. -3

17. a) +6 b) -7 c) +1 d) -2 e) -11 f) 0

18. a) +4 b) No

19. a) The number of dots in each symbol on the turtle's back is equal to the number in the corresponding location of the magic square. The magic sum is 15.

b) -3

c) Yes, +3

d) Answers may vary. For example,

-8	+2	0
+6	-2	-10
-4	-6	+4

20. a) +3, 0, -1

b) +6, +3, +2, 0, -1, -2

c) +9, +6, +5, +3, +2, +1, 0, -1, -2, -3

d) Answers may vary.

e) Answers may vary.

## 9.2 Add Integers, pages 320–321

5. a)  $(+5) + (+4) = +9$

b)  $(-4) + (+4) = 0$

c)  $(+8) + (-9) = -1$

6. a)  $(-6) + (-2) = -8$

b)  $(+6) + (-4) = +2$

c)  $(-1) + (+7) = +6$

7. a)  $(+5) + (+5) = +10$

b)  $(-3) + (-6) = -9$

c)  $(+4) + (-10) = -6$

d)  $(-7) + (+12) = +5$

8. a)  $(-4) + (+8) = +4$

b)  $(-4) + (-6) = -10$

c)  $(+5) + (-9) = -4$

d)  $(+10) + (-8) = +2$

9. \$8

10.  $-14^{\circ}\text{C}$

11. a)  $+7^{\circ}\text{C}$  b)  $-20^{\circ}\text{C}$

12. a)  $-16\text{ m}$  b)  $-90\text{ m}$

13. 0; The numbers are equal in value, but opposite in sign. They are opposites.

14. a) Answers may vary. For example,  $-2, +1, -3, +2, -4, +3, -5, +4$

b) Yes. There is an infinite number of integers for which the sum of the 2 integers is  $-1$ .

15. a)  $(+9) + (-5) = +4$

$(+8) + (-4) = +4$

$(+7) + (-3) = +4$

$(+6) + (-2) = +4$

b) The first integer decreases by 1 and the second integer increases by 1 from the top of the pattern to the bottom of the pattern.

c)  $(+5) + (-1) = +4$

$(+4) + (0) = +4$

$(+3) + (+1) = +4$

16.  $-5, -4, -2, -1, 0, +1, +2, +3, +4, +5$

17. a)  $+5, +4$ . As the value of the integer that is added to  $+6$  decreases, the value of the integer answer decreases by 1.

b)  $(+2) + (+2) = +4$

$(+2) + (+1) = +3$

$(+2) + (0) = +2$

$(+2) + (-1) = +1$

$(+2) + (-2) = 0$

$(+2) + (-3) = -1$

$(+2) + (-4) = -2$

c)  $(-3) + (+2) = -1$

$(-3) + (+1) = -2$

$(-3) + (0) = -3$

$(-3) + (-1) = -4$

$(-3) + (-2) = -5$

$(-3) + (-3) = -6$

$(-3) + (-4) = -7$

$(-3) + (-5) = -8$

18. a) Never true. The sum of 2 negative integers is a negative integer,  $(-5) + (-2) = -7$ .

b) Sometimes true. The sum  $(+3) + (-2) = +1$ , but the sum  $(+3) + (-3) = 0$ .

c) Always true. The sum  $(+5) + 0 = +5$ . When 0 is added to any integer, the value of the integer does not change.

d) Sometimes true. The sum  $(+3) + (-5) = -2$ , but the sum  $(+3) + (-3) = 0$ .

19. a) Answers may vary. For example, integer chips. Model the addition with 6 blue chips and 4 red chips.

$(-6) + (+4) = -2$

b) Answers may vary. For example, a number line. The addition would involve too many chips to model with integer chips.  $(+90) + (-140) = -50$

20. a)  $+14$  b)  $-16$  c)  $+2$  d)  $-9$

21. a)  $(+4) + (+5) = +9$

b)  $(-6) + (+4) = -2$

c)  $(-2) + (-5) = -7$

d)  $+6 = (+9) + (-3)$

e)  $(+8) + (-6) = +2$

f)  $-1 = (-5) + (+4)$

22. a)  $-6 = (-1) + (-2) + (-3)$ ,  $-12 = (-3) + (-4) + (-5)$ ,  $-15 = (-4) + (-5) + (-6)$ ,  $+3 = 0 + (+1) + (+2)$ ,  $+6 = (+1) + (+2) + (+3)$

b) Answers may vary. Any number that is the sum of 3 consecutive integers is a multiple of 3 or  $-3$ .

23. \$28

## 9.3 Explore Integer Subtraction, pages 327–329

5. a)  $(+5) - (+3) = +2$

b)  $(-7) - (-4) = -3$

6. a)  $(-7) - (-1) = -6$

b)  $(+6) - (+6) = 0$

7. a)  $(-5) - (+1) = -6$

b)  $(+5) - (+9) = -4$

8. a)  $(+3) - (-4) = +7$

b)  $(-4) - (-9) = +5$

9. a)  $+2$  b)  $+7$  c)  $-12$  d)  $+3$

10. a)  $-4$  b)  $+6$  c)  $-11$  d)  $-5$

11. a)  $+2, -2$  b)  $+4, -4$  c)  $+4, -4$  d)  $+2, -2$

12. a)  $+4, -4$  b)  $+5, -5$  c)  $+4, -4$  d)  $+2, -2$



**13. a)** The difference of +12 h means that Perth, Australia is 12 h ahead of Bermuda; The difference of -12 h means that Bermuda is 12 h behind Perth, Australia.

**b)** The difference of +2 h means that Lima, Peru is 2 h ahead of Calgary, Alberta; the difference of -2 h means that Calgary, Alberta is 2 h behind Lima, Peru.

**c)** The difference of +11 h means that Lagos, Nigeria is 11 h ahead of Honolulu, Hawaii; the difference of -11 h means that Honolulu, Hawaii is 11 h behind Lagos, Nigeria.

**d)** The difference of +4 h means that Halifax, Nova Scotia is 4 h ahead of Dawson, Yukon Territory; the difference of -4 h means that Dawson, Yukon Territory is 4 h behind Halifax, Nova Scotia.

**14.** The difference of +6°C means that the afternoon temperature is 6°C above the morning temperature; the difference of -6°C means that the morning temperature is 6°C below the afternoon temperature.

**15. a)** 4 points **b)** 5°C **c)** \$6

**16.** 15 floors down

**17.** Answers may vary. For example, the difference is the opposite of the original non-zero integer.

**18. a)**

$(+3) - (+2) = +1$	$(+2) - (+3) = -1$
$(+4) - (-1) = +5$	$(-1) - (+4) = -5$
$(-3) - (+5) = -8$	$(+5) - (-3) = +8$
$(-2) - (-7) = +5$	$(-7) - (-2) = -5$

**b)** Answers may vary. For example, the answers are opposites. The numerals are the same, but they are opposite in sign.

**c)** No. The order for this subtraction is given by the question. If the integers were subtracted in the other order, the answer would have the opposite sign.

**19. a)** +3 **b)** +1 **c)** 0 **d)** -5

**20. a)** +5 **b)** +5 **c)** +5 **d)** -4

**21. a)**  $3\frac{1}{2}$  h behind **b)**  $4\frac{1}{2}$  h ahead

## 9.4 Subtract Integers, pages 333–335

**5. a)**  $(+3) - (+4) = (+3) + (-4)$

**b)**  $(-1) - (-10) = (-1) + (+10)$

**c)**  $(-4) - (+5) = (-4) + (-5)$

**6. a)**  $(-7) - (-6) = (-7) + (+6)$

**b)**  $(+6) - (-3) = (+6) + (+3)$

**c)**  $(-9) - (+9) = (-9) + (-9)$

**7. a)** +6;  $(+2) - (-4) = (+2) + (+4) = +6$

**b)** +4;  $(-3) - (-7) = (-3) + (+7) = +4$

**8. a)** -10;  $(-4) - (+6) = (-4) + (-6) = -10$

**b)** 0;  $(-8) - (-8) = (-8) + (+8) = 0$

**9. a)** -6 **b)** +5 **c)** -13 **d)** +8

**10. a)** +10 **b)** -7 **c)** -4 **d)** +2

**11. a)** +2, -2 **b)** +2, -2 **c)** +5, -5

**12. a)** -2, +2 **b)** +6, -6 **c)** +1, -1

**13.** Estimate: 1400 m; The difference of +1403 m means that Cypress Hills is 1403 higher in elevation than Lake Athabasca; the difference of -1403 m means that Lake Athabasca is 1403 m lower in elevation than Cypress Hills.

**14.** The difference of +108°C means that the temperature in Midale, Saskatchewan was 108°C higher than the temperature in Snag, Yukon Territory; the difference of -108°C means that the temperature in Snag, Yukon Territory was 108°C lower than the temperature in Midale, Saskatchewan.

**15.** The difference of +32 s means that the rocket launch at T minus 12 was 32 s faster than the rocket launch at T minus 44; the difference of -32 s means that the rocket launch at T minus 44 was 32 s slower than the rocket launch at T minus 12.

**16.** estimate: 600 m, calculate: 614 m

**17.** 396°C

**18.** +4, +5. As the integer that is subtracted decreases by 1, the integer that is the answer increases by 1.

**19. a)**  $(+1) - (-1) = +2$

$(+2) - (-2) = +4$

$(+3) - (-3) = +6$

$(+4) - (-4) = +8$

**b)** Subtracting the opposite is the same as adding the first integer to itself. **c)** +774

**20. a)** 7 units **b)** 9 units **c)** 9 units **d)** 5 units

**21.**  $P = 16$  units,  $A = 16$  square units

**22. a)**  $(+3) - (-2) = +5$

$(+2) - (-1) = +3$

$(+1) - (0) = +1$

$(0) - (+1) = -1$

**b)** Answers may vary. The first integer is decreasing by 1. The integer that is subtracted is increasing by 1. The integer answer is decreasing by 2.

**c)**  $(-1) - (+2) = -3$ ,  $(-2) - (+3) = -5$ ,

$(-3) - (+4) = -7$

**23. a)**  $(+8) - (+5) = +3$

**b)**  $(-1) - (+4) = -5$

**c)**  $(-2) - (-9) = +7$

**d)**  $-6 = (-7) - (-1)$

**e)**  $(+2) - (+2) = 0$

**f)**  $-2 = (+5) - (+7)$

**24.** +13, -3;  $(-3) - (+5) = -8$ ;  $(+5) - (+13) = -8$

## 9.5 Apply Integer Operations, pages 339–341

**3.** +30°C

**4.** -5°C

**5.** 10 203 m

**6.** -20 m; 20 m below the Fraser River

**7.** The wind speed decreased by 20 km/h.

**8. a)** loss of \$4 million

**b)** \$20 million better

**9. a)** Add 3 to each preceding number; +13, +16, +19

**b)** Subtract 4 from each preceding number; -7, -11, -15

**c)** Add 2 to each preceding number; -3, -1, +1

**d)** Subtract 5 from each preceding number; 0, -5, -10

**10.**  $-11, -4$ ;  $(-11) + (-4) = -15$ ;  $-4 - (-11) = +7$ ;  
 $(-11) - (-4) = -7$

**11.** Answers may vary.

$(+3) + 0 = +3$  or  $(+3) - 0 = +3$

$(+4) + 0 = +4$  or  $(+4) - 0 = +4$

$(+5) + 0 = +5$  or  $(+3) - 0 = +5$

$(+6) + 0 = +6$  or  $(+6) - 0 = +6$

**12. a)**  $-2$

**b)** 6 more strokes

**c)** Annika took 64 strokes to complete the first round.

Michelle took 70 strokes to complete the first round.

**13. a)**  $+15 = (+7) + (+8)$ ,  $-9 = (-4) + (-5)$ ,

$-1 = 0 + (-1)$ ,  $-25 = (-12) + (-13)$

**b)** All even integers. **c)**  $+1, -1$

**14. a)**  $-2$  **b)**  $+1$  **c)**  $-4$  **d)**  $+10$  **e)**  $0$  **f)**  $-11$

**15.** Answers may vary.

**16. a)** 13 MPs **b)** 148 in favour and 147 against

**17. a)** 11 a.m. **b)** 5 p.m. Tuesday **c)** 6 h

**18. a)** 62 years **b)** 15 B.C.E. **c)** 18 C.E.

### Chapter 9 Review, pages 342–343

**1.**  $-2$

**2.**  $+1, -1$

**3. a)**  $(+7) + (-4) = +3$

**b)**  $(-6) + (+5) = -1$

**c)**  $(+5) + (-8) = -3$

**4. a)**  $(-5) + (-3) = -8$

**b)**  $(+4) + (-4) = 0$

**c)**  $(+6) + (-3) = +3$

**d)**  $(-9) + (+4) = -5$

**5.** The sum will be positive if the larger numeral is positive.  $(+5) + (-3) = +2$ . The sum will be negative if the larger numeral is negative.  $(-4) + (+3) = -1$ . The sum is zero if the integers are opposites.

**6.**  $(+4) + (-6) = (-2)$  The pelican dove 2 m below the surface of the water.

**7. a)**  $(-4) + (-5) = -9$

**b)**  $(+6) + (-3) = +3$

**8. a)**  $(-3) + (+3) = 0$

**b)**  $(+7) + (-2) = +5$

**c)**  $(-4) + (+12) = +8$

**d)**  $(+6) + (-8) = -2$

**9.** Answers may vary.  $(-5) + (-4)$ ,  $(-6) + (-3)$ ,

$(-7) + (-2)$ ,  $(-8) + (-1)$

**10.** 2 m below sea level

**11. a)**  $(-7) - (+2) = -9$

**b)**  $(-4) - (-10) = +6$

**12. a)**  $(-7) - (-5) = -2$

**b)**  $(+4) - (-3) = +7$

**c)**  $(+3) - (+8) = -5$

**d)**  $(-1) - (+6) = -7$

**13.** 15 h

**14. a)**  $-3$ ;  $(+4) - (+7) = (+4) + (-7) = -3$

**b)**  $-2$ ;  $(-6) - (-4) = (-6) + (+4) = -2$

**15. a)**  $-3$  **b)**  $+2$  **c)**  $-9$  **d)**  $+13$

**16.** The difference of  $+9259$  m means that Mt. Everest is 9259 m higher in elevation than the Dead Sea; the difference of  $-9259$  m means that the Dead Sea is 9259 m lower in elevation than Mt. Everest.

**17. a)** Add  $+6$  to each preceding number.  $+27, +33, +39$

**b)** Subtract 10 from each preceding number.  $0, -10, -20$

**18. a)** 7 strokes **b)** 2 strokes **c)** 7 under par **d)** 281 strokes

## Chapter 10

### 10.1 Describe Patterns, pages 354–357

**5. a)** Answers may vary. Each figure has two more squares than the previous figure.



**6. a)** Each figure has 3 more dots than the previous figure.

**b)** 15

**7. a)**  $0.\overline{16}, 1.\overline{16}, 2.\overline{16}, 3.\overline{16}$

**b)** Answers may vary. In the fraction pattern,  $\frac{6}{6}$  is added to each fraction to get the next fraction in the pattern. In the decimal pattern, 1 is added to each decimal number to get the next decimal number in the pattern.

**c)**  $\frac{25}{6}$

**d)**  $4.1\overline{66}$ ... or  $4.\overline{16}$

**8. a)** Answers may vary. In the fraction pattern, the value of the numerator increases by 1. In the decimal pattern, the repeating decimal is the numerator of the fraction multiplied by 9. Each repeating decimal number increases by  $0.0\overline{9}$ .

**b)**  $\frac{4}{11}$ . **C**  $4 \div 11 \equiv 0.363636364$

**c)**  $\frac{6}{11}$ . The numerator of 6 multiplied by 9 is 54, which is the repeating decimal.

**d)**  $\frac{9}{11}$ . Answers may vary. For example, the numerator of 9 multiplied by 9 is 81, which is the repeating decimal.

**9. a)** 400. Subtract 400 from the previous number.

**b)** 4.6 Add 1.1 to the previous number.

**c)**  Add one side to the previous polygon.

**d)** 

**10. a)**

<b>A</b>	1	2	3	4
<b>B</b>	10	20	30	40
<b>C</b>	100	200	300	400
<b>D</b>	1000	2000	3000	4000

**b)** A; Add 1 to the previous number. B; Add 10 to the previous number. C; Add 100 to the previous number. D; Add 1000 to the previous number.

**11. a)** Squares: The number of squares in the figure increases by the figure number. Colour: Alternate between adding green and red squares by adding 2 green, then 3 red, 4 green, 5 red, and so on.

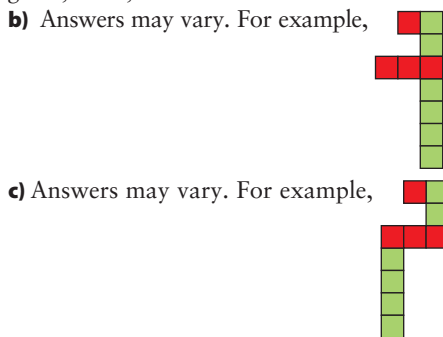

**c)** Answers may vary. For example,

**12. a)** The numerator is the repeating decimal.  
**b)**  $0.\overline{8}$ , 1  
**c)** The decimal equivalent of  $\frac{9}{9}$  is not a repeating decimal.  
**d)** Answers may vary. For example, the pattern of repeating decimals continues.

**e)**

Fraction	Decimal Number	Fraction	Decimal Number
$\frac{5}{9}$	$0.\overline{5}$	$\frac{12}{9}$	$1.\overline{3}$
$\frac{6}{9}$	$0.\overline{6}$	$\frac{13}{9}$	$1.\overline{4}$
$\frac{7}{9}$	$0.\overline{7}$	$\frac{14}{9}$	$1.\overline{5}$
$\frac{8}{9}$	$0.\overline{8}$	$\frac{15}{9}$	$1.\overline{6}$
$\frac{9}{9}$	1	$\frac{16}{9}$	$1.\overline{7}$
$\frac{10}{9}$	$1.\overline{1}$	$\frac{17}{9}$	$1.\overline{8}$
$\frac{11}{9}$	$1.\overline{2}$	$\frac{18}{9}$	2

**f)**  $2.\overline{1}$

**13. a)** Answers may vary.

1	2	3
11	12	13
21	22	23

**b)** Answers may vary.  $1 + 12 + 23 = 36$ ,  
 $3 + 12 + 21 = 36$ . The two sums are equal.  
**c)** Answers may vary.  
**d)** Answers may vary. The sum of one diagonal equals the sum of the other diagonal in the same  $3 \times 3$  square.  
**e)** Answers may vary. The sum of one diagonal equals the sum of the other diagonal in the same  $2 \times 2$  square.  
**14. a)** Answers may vary.

2	3
9	10

**b)** Answers may vary.  $2 \times 10 = 20$ ,  $3 \times 9 = 27$   
**c)** Answers may vary.  
**d)** Answers may vary. The difference between the product of the diagonals in each  $2 \times 2$  square is 7.

**15. a)**  $0.\overline{3}$ ,  $0.\overline{6}$ , 1,  $1.\overline{3}$ ,  $1.\overline{6}$ , ...

**b)** Answers may vary.

**16. a)** 162

**b)** If there are tens digits in the six numbers, add them and then multiply this value by 10 to get value #1. Add the ones digits in the six numbers to get value #2. Add values #1 and #2 to get the sum of the six numbers.

**c)**  $2 + 2 + 2 + 3 + 3 + 4 = 16$

$16 \times 10 = 160$

$6 + 7 + 8 + 8 + 9 + 0 = 38$

$160 + 38 = 198$

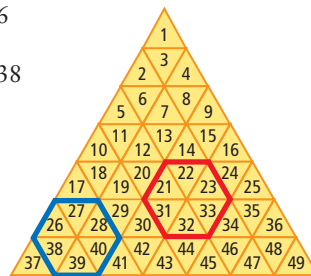

**17.** 5, 8, 11

**18.** 188, 176, 164, 152

## 10.2 Variables and Expressions, pages 361–364

**4. a)**

Base	1	2	3	4	5	6
Perimeter	4	8	12	16	20	24

**b)** Answers may vary. For example, the perimeter is four times the number of toothpicks in the base.

**c)**  $4b$

**d)** 40

**5. a)** Answers may vary. In each figure, the number of dots is five times the figure number. The number of black dots is four times the number of red dots. The number of line segments is four times the figure number. The number of red dots is equal to the figure number. The number of black dots is four times the figure number.

**b)** 100

**c)**

Figure Number	1	2	3	4	5	6	7
Number of Black Dots	4	8	12	16	20	24	28

**d)**  $4f$

**e)** 204

**6. a)**  $n$  represents the number of students trying out;  $n - 7$

**b)**  $f$  represents the number of people in Alice's family;  $f - 5$

**c)**  $m$  represents the number of family members;  $2m$

**7. a)**  $3w$  **b)**  $v - 8$  **c)**  $A + 15$  **d)**  $\frac{b}{4}$  **e)**  $2l - 2$

**8. a)**  $1.79p$  **b)**  $1.35c$  **c)**  $1.79p + 1.35$

**9.** Answers may vary. For example,

**a)** Each magazine costs \$4. **b)** the number of magazines

**10.** Answers may vary. **a)**

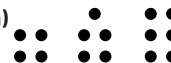

**b)**  $b$  represents the figure number.

**11. a)**  $30 - x$  **b)**  $n - 11$  **c)**  $p - x$

**12. a)**  $w + 3$ ; variable:  $w$ ; constant: 3; coefficient: 1

**b)**  $2p$ ; variable:  $p$ ; coefficient: 2

**c)**  $\frac{t}{2}$  or  $0.5t$ ; variable:  $t$ ; coefficient:  $\frac{1}{2}$  or 0.5

13. a)  $h$ ; The number of hours Salma babysat.  
 b) bonus of \$3 c) \$38  
 14. a) the sum of the number of loaves of white and brown bread  
 b) the number of loaves of white bread ordered over a number of days  
 15. a)  $25x$  b)  $10y$  c)  $25x + 10y$   
 16. a) variable:  $a$ ; coefficient: 7; constant: 8  
 b) variable:  $h$ ; coefficient: 3; constant: 100  
 c) variable:  $q$ ; coefficient: 8  
 d) variable:  $n$ ; coefficient:  $\frac{1}{3}$ ; constant: 5  
 17. a) Answers may vary. The numbers increase by 10 down the H.  
 b) 168  
 c) Multiply the middle number by 7.  
 d) Answers may vary.  $7 \times 26 = 182$

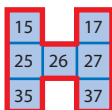

- e)  $7m$   
 18. a)  $5t$  b) B  
 19. a) Patterns A and B: 602 units  
 b)–c) Pattern A:  $4h + 2$ ; Pattern B:  $4(h - 1) + 6$

### 10.3 Evaluate Expressions, pages 368–371

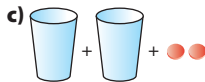
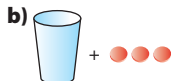
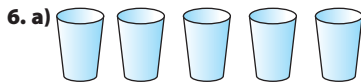
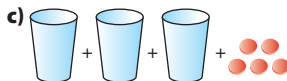
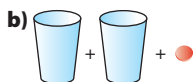

7. a)  $c + 4$  b)  $3c + 2$   
 8. a)  $2c + 4$  b)  $3c + 1$  c)  $3c$   
 9. a) 8 b) 3 c) 17  
 10. a) 11 b) 3 c) 17

11. a) 

Figure Number	Perimeter
1	5
2	10
3	15
4	20
5	25
6	30

 b) 60

12. a) 

Bookcase	Number of Shelves
1	4
2	8
3	12
4	16
5	20

- b)  $4b$  c) bookcase number

13. 

$x$	$3x + 4$
0	4
1	7
2	10
3	13
4	16

14. a) 

Figure Number	Number of Toothpicks
1	6
2	11
3	16
4	21
5	26
6	31
7	36

- b) 46 c) 501  
 15. a)  $14 \text{ cm}^2$  b)  $56 \text{ cm}^2$   
 16. a) 200 mL b)

Pour	Volume (mL)
1	100
2	200
3	300
4	400
5	500
6	600
7	700

- c)  $100p$  d) number of pours e) 1500 mL  
 17. a) 17 b) 7 c) 22 d) 20

18. a) 

Figure Number	Number of Red Squares	Number of Black Squares
1	2	2
2	3	4
3	4	6
4	5	8
5	6	10
6	7	12

- b)  $2f$  where  $f$  is the figure number

19. a) 

Triangle Number	$3t + 6$	$t + t + t + 6$
1	9	9
2	12	12
3	15	15
4	18	18
5	21	21

- b) They are both correct because  $3t + 6 = t + t + t + 6$ .

20. a) 14 cm b)  $\frac{p - 2q}{2}$

21. a)

	Figure 5	Figure 6
Black	20	24
White	25	30

b)  $4f$  where  $f$  is the figure number

c) Answers may vary.

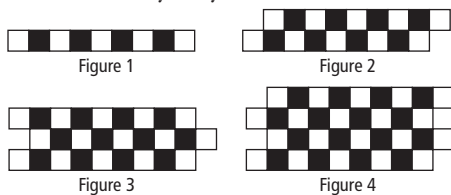

d) Answers may vary.

### 10.4 Graph Linear Relations, pages 378–381

3. a)

Number of Red Tiles, $x$	Number of White Tiles, $y$
1	2
2	4
3	6
4	8
5	10

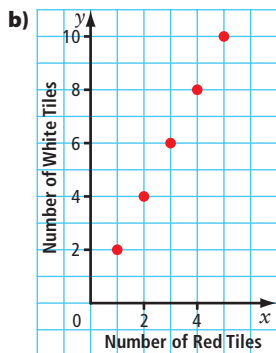

c) Words: The pattern of points forms a straight line, starting at (1, 2). The  $y$ -coordinate is 2 times the  $x$ -coordinate.

Horizontal and Vertical Distances: The points increase by 1 unit right, then 2 units up, starting at (1, 2).

Relationship: The number of red tiles is  $x$ . The number of white tiles is  $y$ . The coordinates of the points are  $(x, y)$ .

The relationship between  $x$  and  $y$  is linear. It can be written as  $(x, 2x)$  or  $y = 2x$ .

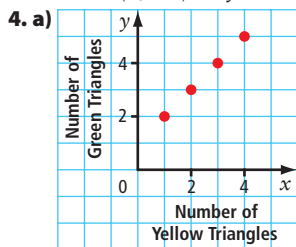

b) Words: The pattern of points forms a straight line, starting at (1, 2). The  $y$ -coordinate is one more than the  $x$ -coordinate. Horizontal and Vertical Distances: The points increase by 1 unit right, then 1 unit up, starting at (1, 2). Relationship: The number of yellow triangles is  $x$ . The number of green triangles is  $y$ . The coordinates of the points are  $(x, y)$ . The relationship between  $x$  and  $y$  is linear. It can be written as  $(x, x + 1)$  or  $y = x + 1$ .

5. a)

Day, $d$	Number of Visitors, $v$
1	4
2	5
3	6
4	7
5	8
6	9
7	10

b) Words: The pattern of points forms a straight line, starting at (1, 4). The  $y$ -coordinate is 3 more than the  $x$ -coordinate.

Horizontal and Vertical Distances: The points increase by 1 unit right, then 1 unit up, starting at (1, 4).

Relationship: The number of days is  $d$ . The number of visitors is  $v$ . The coordinates of the points are  $(d, v)$ . The relationship between  $d$  and  $v$  is linear. It can be written as  $(d, d + 3)$  or  $v = d + 3$ . c) 15

6. a)

Number of Lifeguards, $x$	Number of Swimmers, $y$
1	20
2	40
3	60
4	80
5	100
6	120

b) Words: The pattern of points forms a straight line, starting at (1, 20). The  $y$ -coordinate is 20 times the  $x$ -coordinate.

Horizontal and Vertical Distances: The points increase by 1 unit right, then 20 units up, starting at (1, 20).

Relationship: The number of lifeguards is  $x$ . The number of swimmers is  $y$ . The coordinates of the points are  $(x, y)$ . The relationship between  $x$  and  $y$  is linear. It can be written as  $(x, 20x)$  or  $y = 20x$ .

c) 240

7. Answers may vary.

a) expression:  $7x$ ; linear relation:  $y = 7x$

b) expression:  $x - 2$ ; linear relation:  $y = x - 2$

8. a) The number of pucks is  $p$ . The total cost is  $C$ . The relationship between  $p$  and  $C$  is linear. It can be written as  $(p, 2p)$  or  $C = 2p$ . b) \$18 c)  $C = 2p + 30$

9. Yes, Faheen is correct. When you substitute the values of  $x$  when  $x = 1, 2, 3, 4$ , the  $y$  values for Graph A match  $y = 8 - 2x$  and the  $y$  values for Graph B match  $y = 8 - x$ .

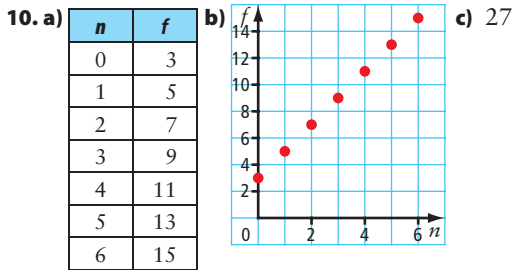

11. a) Graph 2 b) Graph 1

12. a) 

Number of Sales (1000s)	Monthly Earnings (\$)
1	1250
2	1300
3	1350
4	1400
5	1450

b) Extend the line made by the points on the graph to  $x = 8$ . Then determine that the  $y$  value at that point is 1600.

c) 10 000 widgets

13. a) 

Sightings After 1606	Year
1	1682
2	1758
3	1834
4	1910
5	1986

b) 5 times c) 2062

d)  $76n + 1606$ ;  $n$  stands for the sighting number of the comet since 1606.

e)  $76n + 1606 = 76(15) + 1606 = 2746$

14. a) 

Row, $r$	Number of Seats, $s$
1	16
2	20
3	24
4	28
5	32
6	36

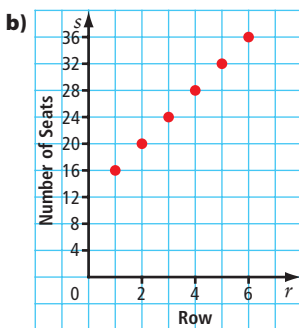

c) The row number is  $r$ . The number of seats is  $s$ . The relationship between  $r$  and  $s$  is linear. It can be written as  $(r, 4r + 12)$  or  $s = 4r + 12$ .

d) Method 1:  $4r + 12 = 4(15) + 12 = 72$

Method 2: As the row number increases by 1, the number of seats increases by 4. From row 6 to row 15, there are 9 rows. By the 9th row, the number of seats increases by  $9 \times 4 = 36$  seats. There are 36 seats in the sixth row.

The number of seats in the fifteenth row is  $36 + 36 = 72$ .

15. a) b) 

Number of Triangles, $t$	Number of Sticks, $s$
1	3
2	5
3	7
4	9
5	11
6	13
7	15
8	17

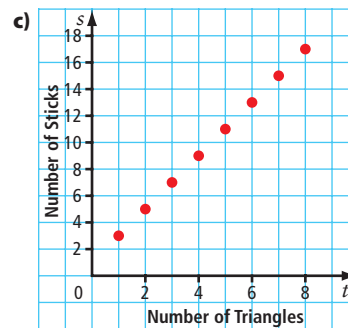

d) The number of triangles is  $t$ . The number of sticks is  $s$ . The relationship between  $t$  and  $s$  is  $(t, 2t + 1)$  or  $s = 2t + 1$ .

e) 4015 sticks

### Chapter 10 Review, pages 382–383

1. variable

2. expression

3. constant

4. numerical coefficient

5. linear relation

6. a) Start with a row of 7 cubes, then put 5 cubes on top, then put 3 cubes on top of that, and then 1 cube on top of that.

b) 25

7. a)  $0.\bar{5}$ ,  $0.\bar{7}$  b)  $\frac{4}{9}$  c)  $\frac{8}{9}$

8. a) 0.3888... or  $0.3\bar{8}$  Determine the pattern of adding  $0.\bar{1}$  to the previous decimal number in the pattern:

$0.2\bar{7} + 0.\bar{1} = 0.3\bar{8}$ .

b)  $0.0\bar{5}$

9. a) 4 b) down

c) Up. In all figures with odd numbers the last triangle is pointing up, and 35 is an odd number.

10. a)  $b - 5$ , where  $b$  is the number of birds sitting in the tree before five birds fly away

b)  $8C$ , where  $C$  is the cost of a can of soup

c)  $r + 3$ , where  $r$  is the length of rope Peter has

d)  $\frac{8}{d}$ , where  $d$  is the number of dogs



11. a) the total number of wheels

b) the length of one car

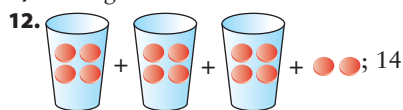

13. a)

Number of Samosas Sold	Total Cost (\$)
1	2.50
2	5.00
3	7.50
4	10.00
5	12.50
6	15.00

b)  $2.5s$  where  $s$  represents the number of samosas sold

c) \$22.50

14. a) 13 b) 18.1 cm<sup>2</sup> c) 32 mm

15. a)

Number of Days, $d$	Total Cost (\$), $C$
3	1
4	2
5	3
6	4
7	5

b) Words: The pattern of points forms a straight line, starting at (3, 1). The C-coordinate is 2 less than the x-coordinate.

Horizontal and Vertical Distances: The points increase by 1 unit right, then 1 unit up, starting at (3, 1).

Relationship: The number of days is  $d$ . The total cost is  $C$ . The coordinates of the points are  $(d, C)$ . The relationship between  $d$  and  $C$  is linear. It can be written as  $(d, d - 2)$  or  $C = d - 2$ .

c) 0; It does not make sense because that means it is free to play the game for two days.

d) \$46; Substitute  $d = 48$  into the expression  $d - 2$ .

16. a) Graph 1 b) Graph 2

6. a)  $2x + 3 = 7$ , equation, numerical coefficient: 2,

variable:  $x$ , constant: 3, 7

b)  $7 + 2x$ , expression, numerical coefficient: 2, variable:  $x$ , constant: 7

c)  $15 = 5 + 2x$ , equation, numerical coefficient: 2, variable:  $x$ , constant: 5, 15

7. a)  $x + 7$ , 11;  $x + 7 = 11$

b)  $2x - 3$ , 5;  $2x - 3 = 5$

c) 6,  $1 + 5x$ ;  $6 = 1 + 5x$

8. a)  $x - 4$ , 5;  $x - 4 = 5$

b)  $6 + 3x$ , 9;  $6 + 3x = 9$

c) 12,  $4x - 4$ ;  $12 = 4x - 4$

9. a)  $b + 12$  b)  $t - 5$  c)  $a - 52$

10. a)  $3n - 9$  b)  $\frac{f}{5} + 4$  c)  $8(g - 5)$  d)  $\frac{h}{8} - 12$

11. a)  $2a + 4 = 30$  b)  $\frac{m}{2} = 25$  c)  $4h = 600$

12. a) three times a number minus 6

b) six times a number plus eight

c) six times the result of a number minus 3

d) nine more than the product of two and a number.

13. a)  $2x + 2$ ,  $3 + x$

b)  $2x + 2 = 3 + x$

14. a) 12,  $4 + 2m$

b) Use Guess and Check: Try  $m = 4$ ;  $12 = 4 + 2(4)$ ,  $12 = 4 + 8$ ,  $12 = 12$

15. a)

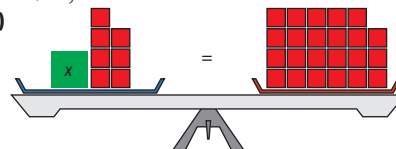

b)  $x + 7 = 23$

c) The variable represents the amount of money that Duncan has now.

d) \$16. Use Guess and Check to find the answer.

## 11.2 Solve One-Step Equations: $x + a = b$ , pages 399–401

4. a)  $z = -3$  b)  $g = 7$  c)  $n = 12$  d)  $k = 3$

5. a)  $b = 3$  b)  $r = 80$  c)  $w = 12$  d)  $h = 2$

6. a) 3 b) 8 c) 4

7. a) 3 b) 6 c) 7

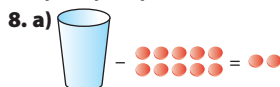

b)  $x - 10 = 2$  c) 12

9. a)  $g = 6$  b)  $w = 0$  c)  $k = 16$  d)  $p = 25$

10. a)  $m = 2$  b)  $k = -5$  c)  $p = 24$  d)  $x = 1$

11. a) The money that Charles has in his pocket; this value is unknown.

b) \$16

12. a)  $x = 5$  is a solution to the equation,  $5 + 10 = 15$

b)  $x = 5$  is not a solution to the equation,  $10 - 5 \neq 15$

c)  $x = 5$  is a solution to the equation,  $5 - 7 = -2$

d)  $x = 5$  is not a solution to the equation,  $42 \neq 37 - 5$

## Chapter 11

### 11.1 Expressions and Equations, pages 393–394

3. a) expression,  $x + 6$

b) equation,  $2x + 2 = 8$

c) expression,  $4x - 3$

d) equation,  $3x + 3 = 6$

4. a) variable:  $x$ , constant: 6

b) numerical coefficient: 2, variable:  $x$ , constant: 2, 8

c) numerical coefficient: 4, variable:  $x$ , constant: 3

d) numerical coefficient: 3, variable:  $x$ , constant: 3, 6

5. a)  $x - 8$ , expression, variable:  $x$ , constant: 8

b)  $3x + 2$ , expression, numerical coefficient: 3, variable:  $x$ , constant: 2

c)  $x - 2 = 8$ , equation, variable:  $x$ , constant: 2, 8

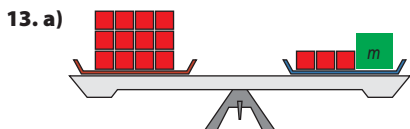

b)  $t + 8 = 12$  c)  $m = 9$



b)  $t + 8 = 12$  c) \$4

15. a)  $k - 12 = 48$  b) 60 km/h

16. a)  $c + 15 = 25$  b) 10 years

17. a)  $e - 24 = 86$  b) 110 medals

18. 5 binders;  $3x + 5 = 20$

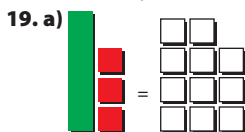

b)  $x + 3 = -11$  c) -14

d) Answers may vary. It is difficult to represent negative numbers on a scale.

20. a) No. The sum of his age and years of employment is 73, which is less than 85.

b) 54 years old

21. a)  $j + 48 = 188$

b) 140 decibels

c)  $\frac{j}{10} = w$ ; When  $j = 140$ ,  $w = 14$ ; 14 decibels

22. a)  $C = 3 + t$  b) \$7 c) 2 h

### 11.3 Solve One Step Equations: $ax = b$ , $\frac{x}{a} = b$ , pages 406–407

4. a) 3 b) 5

5. a)  $x = 16$  b)  $x = 18$

6. a)  $r = 3$  b)  $g = 8$  c)  $d = 3$  d)  $f = 2$

7. a)  $p = 21$  b)  $v = 25$  c)  $c = 36$  d)  $x = 28$

8. a) 6 b) 3 c) 11 d) 9

9. a)  $r = 9$  b)  $j = 25$  c)  $g = 12$  d)  $t = 3$

10. 7 h

11. a) 6 b) 4 c) 11 d) 4

12. a)  $u = 44$  b)  $c = 156$  c)  $w = 108$  d)  $x = 0$

13. 36 h

14. a) Yes,  $8 \times 3 = 24$  b) Yes,  $10 \times 3 = 30$

c) No,  $7 \times 3 \neq 35$  d) No,  $48 \neq 12 \times 3$

15. a) Yes,  $1 = 8 \div 8$  b) No,  $8 \div 4 \neq 16$

c) Yes,  $4 = 8 \div 2$  d) No,  $8 \div 2 \neq 16$

16. a)  $300t = 6000$  b) 20 min

17. a)  $\frac{b}{2} = 21$  b) 42 years old

18. \$165

19. 7 cm

20. a)  $w + w + 2w + 2w = 240$

b)  $6w = 240$

c)  $w = 40$  m;  $l = 80$  m

21. 5 pencils each

### 11.4 Solve Two-Step Equations: $ax + b = c$ , pages 411–413

4. a)  $x = 8$  b)  $n = 3$

5. a)  $n = 4$  b)  $n = 5$

6. a)  $x = 1$  b)  $x = 3$

7. a)  $s = 2$  b)  $k = 3$  c)  $n = 2$  d)  $w = 4$

8. \$4

9. a) Add 2. b) Subtract 3. c) Subtract 10. d) Add 5.

10. a) Divide by 6. b) Divide by 3.

c) Divide by 2. d) Divide by 9.

11. a)  $r = 2$  b)  $m = 1$  c)  $g = 2$  d)  $f = 7$

12. a)  $k = 4$  b)  $x = 3$  c)  $n = 2$  d)  $n = 4$

13. 15 DVDs

14. a) No,  $8(6) + 8 \neq 25$

b) Yes,  $3 + 7(6) = 45$

c) No,  $58 \neq 10(6) - 1$

d) No,  $48 \neq 3(6) + 12$

15. a)  $r = 9$  b)  $y = 20$  c)  $g = 9$  d)  $p = 6$

16. a)  $C$  is the cost for one day at camp;  $s$  is number of students.

b) 20 students

17. a)  $54 = 2p + 6$  b) \$24

18. 6

19. Answers will vary. For example,

a)  $2x + 4 = 16$  b)  $x = 6$  c)  $x = 4$

d) No. Following a different order of operations resulted in a different answer.

e) Substitute the value for the variable into the original equation and see if the left side equals the right side.

20. 23°C

21. a) 25 m/s b) 3 s

### Chapter 11 Review, pages 414–415

1. add, multiply

2. equation

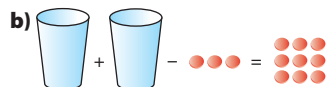

4. a) variable:  $x$ , constant: 3

b) variable:  $r$ , numerical coefficient: 2, constant: 3, 9

5. a)  $x + 4$ , 6;  $x + 4 = 6$

b)  $2x - 3$ , 9;  $2x - 3 = 9$

6. a)  $3k - 1 = 22$

b)  $\frac{b}{2} = 75$



8. a) 5 counters b) 7 counters

9.  $x = 8$

10. a)  $w = 2$  b)  $f = 9$  c)  $g = 20$  d)  $b = 6$   
 11. a)  $t = 28$  b)  $y = 0$  c)  $x = 5$  d)  $p = 17$   
 12. a)  $x + 10 = 24$  b) 14 medals  
 13. 6  
 14.  $h = 12$   
 15. a)  $\frac{x}{2} = 5$  b)  $x = 10$   
 16. a)  $r = 6$  b)  $p = 32$  c)  $w = 7$  d)  $c = 66$   
 17. a) Divide by 3,  $x = 4$ .  
 b) Divide by 4,  $n = 4$ .  
 18. a) Multiply by 5,  $v = 35$ .  
 b) Multiply by 11,  $t = 132$ .  
 19. a)  $\frac{r}{3} = 21$  b) 63 years old  
 20. a)  $x = 6$  b)  $x = 9$   
 21. a)  $g = 12$  b)  $x = 30$  c)  $h = 7$  d)  $p = 7$   
 22. 27 baseball cards,  $2b + 21 = 75$

## Chapter 12

### 12.1 Median and Mode, pages 426–427

4. a) median: 4, mode: 4  
 b) median: 19, modes: 18 and 21  
 c) median: 8, mode: 8  
 5. a) median: 6, mode: 6  
 b) median: 10, no mode  
 c) median: 18, mode: 18  
 6. median: 42, mode: 42  
 7. median: 3, mode: 3  
 8. median: \$15.50, mode: \$14  
 9. median: \$3, mode: \$2  
 10. a) modes: 100 g, 110 g  
 b) median: 102.5 g  
 c) median: 102.5 g, modes: 100 g, 110 g  
 11. a) 170 cm. It is the height with the greatest number of occurrences in the survey.  
 b) median: 165 cm  
 12. Answers may vary. For example, 7, 7, 15, 16  
 13. 1, 2, 3, 4, 4  
 14. a)  $n = 4$   
 b)  $n$  is a whole number,  $n \neq 5$  or  $n \neq 6$   
 15. a)  $n = 4$   
 b)  $n$  is a whole number,  $n \geq 4$   
 16.  $x$  and  $y$  belong to the whole numbers,  $x \geq 5$ ,  $y \geq 5$   
 17. 8, 8, 12, 13, 15

### 12.2 Mean, pages 431–433

3. a) 6 b) 2 c) 60  
 4. a) 7.5 b) 2.3 c) 100  
 5. 8.5  
 6. 1.5 L  
 7. a) 12 points b) 19 points  
 8. a) 4 cm b) 11 cm c) Answers may vary. 48 cm

9. a) 13.8 h  
 b) Answers may vary. Western Canadian teens watch less TV on average than others.  
 c) Answers may vary. The mean for the provinces not listed would have to be more than 14.0, since the mean for the four provinces listed is less than 14.0.  
 d) Answers may vary. 2 h  
 e) Answers may vary. 140 h  
 10. 48.3 homes  
 11. a) 80% b) 89%  
 12. a) 23°C  
 b) Answers may vary. 24°C. The temperature should be closer to the temperature of North Battleford and Yorkton, since the mean includes the cooler temperatures of two northern locations.  
 13. a) 75 b) 100 c) 75%  
 14. 28.8%  
 15. \$9.50  
 16. a) .341  
 b) Answers may vary. Joe has the better updated batting average.  
 c) Joe's batting average is .358 and Mike's batting average is .356.

### 12.3 Range and Outliers, pages 437–438

3. a) 13 b) 12  
 4. a) 24 b) 16  
 5. 23 s  
 6. a) 37 b) 115 c) 888, 1  
 7. a) 666 b) 0, 211 c) no outliers  
 8. a) 8 b) 1 c) 2  
 9. a) 27 min  
 b) 54  
 c) Answers may vary. Vincent took longer to complete the puzzle the first time he completed it because he was unfamiliar with the puzzle.  
 d) 9 min  
 10. a) 20°C b) -13°C c) 33°C  
 11. 108  
 12. 2.0  
 13. a) 4.5  
 b) Answers may vary. No. The range is too small.  
 14. a) range: 15, median: 15, no mode, mean: 14  
 b) range: 15, median: 25, no mode, mean: 24 The median and mean are 10 higher than in part a).  
 c) range: 150, median: 150, no mode, mean: 140 The new measures are ten times the answers to part a).  
 15. a) 1, 4, 4, 6, 10  
 b) 5 min  
 c) Add the times of the five contestants, then divide by 5.  
 16. a)–d) Answers may vary.  
 e) It is not possible to obtain a sum of 19. The highest sum that two single digits can have is  $9 + 9 = 18$ .

## 12.4 The Effects of Outliers, pages 444–445

- 3. a)** 82%  
**b)** median: 40%, mean: approximately 41.9%  
**c)** Answers may vary. 6%, 88%; No. The lower and higher numbers that are outliers are valid data for the students that had at least one song by the musicians.
- 4. a)** 45  
**b)** median: 9, mean: 14.25  
**c)** Answers may vary. 52. Yes. If the sample is to include only students, the age of 52 years old is not representative of a student's age.  
**5. a)** \$8.32  
**b)** median: \$1.59, mean: \$3.11  
**c)** Answers may vary. \$9.61. Yes. The price of \$9.61 may have been an error in recording made by Sharon. She may have meant to record a price of \$1.69.  
**d)** Answers may vary. The median and mode will be lower and more consistent with the rest of the data. median: \$1.49, mean: \$1.49
- 6. a)** 41  
**b)** median: 34, mean: 37.4  
**c)** Answers may vary. 70. Yes. The outlier could be an error in measuring the number of heartbeats in 15 seconds.  
**d)** The median and mode will be lower and more consistent with the rest of the data. median: 33, mean: 33.8
- 7. a)** 80  
**b)** median: 80, mean: 73.75  
**c)** Answers may vary. 20%. No. The score of 20% is still a valid score. It may just indicate that he was unprepared for the test.  
**d)** median: no change, mean: 81.4. There is no change in the median for this question. The mean will be higher and more consistent with the rest of the data.  
**e)** Use the mode or remove the outlier and use the mean.
- 8.** Answers may vary. For example, 0, 47, 48, 49, 50, 51, 52, 53, 100

## 12.5 Choose the Best Measure of Central Tendency, pages 449–451

- 3. a)** median: 5, mode: 7, mean: 4.9  
**b)** Answers may vary. Mean or median. The mode is not a good choice because it represents the highest value in the set of data.
- 4.** mode: 8
- 5. a)** mean: 7.9, modes: 7 and 8  
**b)** mode. The mean does not provide any meaningful information about shoe sizes.
- 6. a)** median: \$145 000, mean: \$523 000  
**b)** median
- 7. a)** mean: 13.6, median: 10, mode: 10  
**b)** Answers may vary. Median or mode. The outliers represented by the teacher's and assistant's ages have been included when calculating the mean.
- 8.** Answers may vary. Contemporary rock; mode, since 31% represents the most popular choice.

- 9. a)** Answers may vary. The mode because it shows the highest success rate.  
**b)** Answers may vary. The mean would likely provide a more realistic measure of the success rate of the disinfectant.
- 10. a)** Grade 6  
**b)** Grade 1: 5, Grade 2: 4, Grade 3: 4.5, Grade 4: 6, Grade 5: 5, Grade 6: 5, Grade 7: 5  
**c)** Grade 4. Answers may vary. On average, each student collected more cans than any of the students in the other grades.
- 11.** 14; The set of numbers is 1, 2, 6, 7, 14.  
**12.** Answers will vary. 29; The set of numbers could be 26, 28, 29, 29.  
**13.** 18  
**14.** mean: 6  
**15. a)** Mode because you could tell Kyle that the most students had 70% on the test.  
**b)** Median because half of the class had scores above 90%.
- 16.** Answers may vary. For example, recommended hours of homework, suggested salary/wage increase.

## Chapter 12 Review, pages 452–453

- median
- mean
- outlier
- range
- mode: 5, median: 5
- mode: 21, median: 20
- Answers may vary. For example, 2, 3, 4, 6, 7, 7
- 2.7 days
- a)** 700 km **b)** 7 days
- a)** 7 **b)** 24 **c)** 11
- a)** highest: 644, lowest: 17  
**b)** 627  
**c)** Answers may vary. 644, 17, 25. The number of fires caused by humans may depend on the number of humans living in the area. The territories have lower populations than the other provinces.
- a)** MB: \$12.62, AB: \$16.16, BC: \$12.11  
**b)** \$4.85  
**13. a)** median: 21, mean: 43.7  
**b)** Answers may vary. 197. Yes. The outlier is a much larger number than the other numbers in the set of data.  
**c)** The median without the outlier will be slightly lower than the median if the outlier is included. The mean without the outlier will be much lower than the mean if the outlier is included. median: 19.5, mean: 18.2
- a)** Class A median: 1, Class B median: 3  
**b)** Class A mean: 3, Class B mean: 2.5  
**c)** Answers may vary. For example, Class B should get the prize because more students brought in cans of food. Class A relied heavily on one student to bring in 37 cans.

Chapters 9–12 Review, pages 458–460

1. a)  $(+6) + (-4) = +2$   
 b)  $(+4) + (-9) = -5$   
 2. a)  $(+4) - (-2) = +6$   
 b)  $(-1) - (-5) = +4$   
 3. a) 0 b) +3 c) -2 d) +16 e) -4 f) +7  
 4.  $+9^\circ\text{C}$   
 5. 413 m deep

6. a) Add 3 to the preceding number starting at 1; 13, 16  
 b) Add 5 to the preceding number starting at 8; 31, 36  
 c) Subtract 3 from the preceding number starting at 17; 5, 2  
 7. a) The denominator of each fraction is 30. Add 3 to the numerator of the preceding fraction starting with the numerator of 2. Add 0.1 to the decimal equivalent of each fraction in the pattern starting with the decimal equivalent of  $\frac{2}{30}$ , which is  $0.0\bar{6}$ .

- b)  $\frac{11}{30}$   
 c)  $0.5\bar{6}$

8. a)

Figure Number	Blue Tiles	White Tiles
1	6	3
2	12	6
3	18	9
4	24	12
5	30	15

- b) The number of blue tiles is twice the number of white tiles.  
 c) Let  $w$  represent the number of white tiles:  $2w$   
 d) 48  
 9. a) 28

b)

Figure Number, $n$	Perimeter
1	6
2	8
3	10
4	12
5	14
6	16

10. a)

Number of Cars, $x$	Number of Riders, $y$
1	4
2	8
3	12
4	16
5	20

- b)  $4x$   
 c) Answers may vary. The points lie in a straight line. The  $y$ -values are four times the  $x$ -values.  
 d) 40 riders  
 11. a)  $2x - 4, 2$   
 b)  $2x - 4 = 2$   
 12. a)  $k = 26$  b)  $p = 0$  c)  $n = 9$  d)  $c = 24$   
 13. a)  $3x + 2 = 11, x = 3$   
 b)  $2x + 3 = 7, x = 2$   
 14. 16 cm  
 15. a)  $C$  represents the cost for one day;  $n$  represents the number of students  
 b) 25 students  
 16. a) 25 b) 26 c) 28  
 17.  $x = 6, y$  is a whole number that cannot equal 4. Or,  $y = 6, x$  is a whole number that cannot equal 4.  
 18. a) 32 min  
 b) 28 min  
 c) Answers may vary. For example, the weather was too stormy for a longer walk.  
 d) 6 min  
 19. 243 points  
 20. 69.2%  
 21. a) \$3.99  
 b) median: \$3.49, mean: \$4.11  
 c) Answers may vary. Median.  
 d) Answers may vary. \$6.98. Yes. The price is double the others. The orange juice container may be larger than the other containers.  
 e) median: \$3.39, mean: \$3.39  
 22. Answers may vary. The mode would advertise the effectiveness of the new chemical to destroy 99% of cockroaches.